

AscenKorea Inc.

## GPS Module Application Notes

Revision: A10

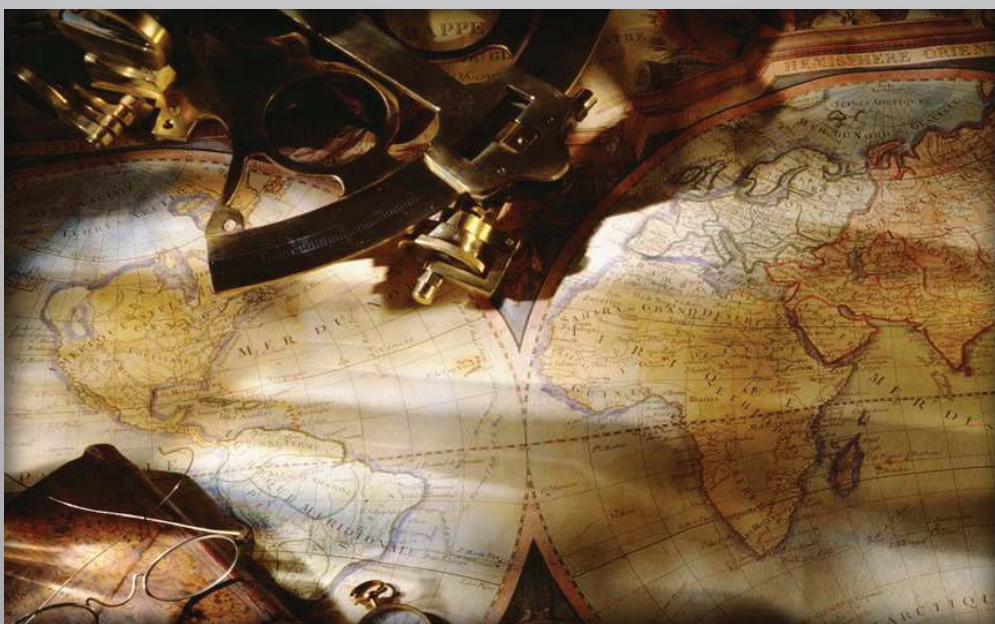

Reference layout, design tips, guides, and cautions for AscenKorea GPS modules.

This document is the exclusive property of AscenKorea Inc. and should not be distributed, reproduced, into any other format without prior permission of AscenKorea Inc. Specifications subject to change without prior notice.

AscenKorea Inc.

Rm. 710, 7F, Halla Sigma Valley B/D, Gasandigital 2Ro 53, Geumcheon-gu, Seoul, Korea  
Tel: +82 02 858 7810 Fax: +82 02 858 7813/ [www.AscenKorea.com](http://www.AscenKorea.com) /[sales@ascen.co.kr](mailto:sales@ascen.co.kr)  
copyright © AscenKorea Inc. All right reserved



## Version History

**Title: AscenKoea GPS Module Application Note**

**Subtitle: GPS Module**

**Doc Type: Technical Document**

Revision	Date	Editor	Description
A00	2009-05-06	Gavin	First Release
A01	2009-07-17	Gavin	Add AKS6B (Fully pin compatible with AKS6)
A02	2009-09-04	Gavin	Add VBAKUP and Layout guideline description Change some description about content. Add Appendix page.
A03	2010-06-15	Brian	Page 10. AKS6X GPS module design restriction Page 23. Add AKS6E reference design Page 26. Add AKMU1 reference design
A04	2010-08-27	Eric	Template Update Introduction Update (+ AKM & AKS) Add 2.2.4 Damping Resistor Add 2.2.5 Ground Segmentation Add 2.2.6 Ground Plane
A05	2010-11-04	Gavin	1. Phased out product related reference design removed 2. Add AKSU1LP reference design (New Product ) 3. Add : 2.1.3 UART 0 (RX/TX) –serial Interface notice items 4. Add : 2.1.6 1PPS- electronic characteristic description 5. Add Appendix page.- III UART to RS232 Interface IV:UART to USB Interface V: How to extend efficiently the transfer distance of 1PPS
A06	2010-12-27	Eric	1. Note on Antenna Power Supply (p.11) 2. Note on Ground Plane (p.16) 3. Add schematics of external antenna short circuit protection for AKMU1 (p.29) 4. Note on Paste Mask (p.31) 5. Appendix VI: Add Evaluation Kit (Ev-Kit) schematics for popular models (p.45)

This document is the exclusive property of AscenKorea Inc. and should not be distributed, reproduced, into any other format without prior permission of AscenKorea Inc. Specifications subject to change without prior notice.



A07	2011-03-23	Gavin	<ol style="list-style-type: none"><li>1. Change company contact information</li><li>2. Add active antenna detect circuit reference design of for AKM U1(p.31)</li><li>3. Add AKMU5LP reference design</li></ol>
A08	2011-05-06	Gavin	<ol style="list-style-type: none"><li>1. Add AKMU5J reference design</li><li>2. Eliminate AKML1 (EOL) , AKS5 (EOL) PA6(EOL)</li><li>3. Add AKS6E and AKSU1LP about Antenna Switch query reference design</li><li>4. Add Appendix page: Cautions on Reflow Soldering Process</li><li>5. Add Trace Tool Information on Appendix II: 50ohm matching line</li></ol>
A09	2011-08-09	Delano	Add :The Pin29 and Pin30 are the bottom ground pads(p.46)
A10	2012-05-17	Delano	Over Current Protection LDO modify Over Current Protection Circuit(p.30)

This document is the exclusive property of AscenKorea Inc. and should not be distributed, reproduced, into any other format without prior permission of AscenKorea Inc. Specifications subject to change without prior notice.



## Table of Contents

<b>Attention</b> .....	<b>5</b>
<b>Technical Support</b> .....	<b>6</b>
<b>1. Introduction</b> .....	<b>7</b>
<b>2. General Rules for Design-in</b> .....	<b>7</b>
<b>2.1 Circuit Design</b> .....	<b>7</b>
2.1.1 Power supply Vcc .....	<b>7</b>
2.1.2 VBACKUP (BACKUP_PWR) backup battery .....	<b>8</b>
2.1.3 UART 0 (RX/TX) –Serial Interface .....	<b>10</b>
2.1.4 GND-Ground .....	<b>10</b>
2.1.5 Antenna Design .....	<b>11</b>
2.1.6 1PPS Signal .....	<b>13</b>
2.1.7 Design Restriction .....	<b>14</b>
<b>2.2 Layout Guideline</b> .....	<b>15</b>
2.2.1 Clearance .....	<b>15</b>
2.2.2 Placement .....	<b>15</b>
2.2.3 Trace .....	<b>16</b>
2.2.4 Damping Resistors .....	<b>16</b>
2.2.5 Ground Segmentation .....	<b>17</b>
2.2.6 Ground Plane .....	<b>17</b>
<b>3. Reference Design and Noise</b> .....	<b>19</b>
3.1 AKML3 .....	<b>19</b>
3.2 AKS2 .....	<b>20</b>
3.3 AKS4 .....	<b>22</b>
3.4 AKS6B/AKS6E .....	<b>23</b>
3.5 AKMU1 .....	<b>26</b>
3.6 AKSU1LP .....	<b>31</b>
3.7 AKMU5LP .....	<b>32</b>
3.8 AKMU5J .....	<b>35</b>
<b>4. Thermal Profile for SMD Modules</b> .....	<b>39</b>
<b>5. Troubleshooting</b> .....	<b>40</b>
<b>6. Contact</b> .....	<b>42</b>
<b>Appendix I: Super Capacitor Design</b> .....	<b>43</b>
<b>Appendix II: About 50 ohm Matching Line</b> .....	<b>44</b>
<b>Appendix III: UART to RS232 Interface</b> .....	<b>45</b>
<b>Appendix IV: UART to USB Interface</b> .....	<b>46</b>
<b>Appendix V: How to efficiently transfer 1PPS through extended distances</b> .....	<b>47</b>
<b>Appendix VI: Evaluation Kit (EV-KIT) Schematics</b> .....	<b>53</b>
<b>Appendix VII: Cautions on Reflow Soldering Process</b> .....	<b>57</b>

This document is the exclusive property of AscenKorea Inc. and should not be distributed, reproduced, into any other format without prior permission of AscenKorea Inc. Specifications subject to change without prior notice.



## Attention

---

Please read carefully before you start:

- ▶ Global Positioning System (GPS) is the property of American Ministry of National Defense, and they held full responsibilities in regard to the preciseness and the maintenance of the entire system. Any changes they have made may have significant impacts on the capabilities and preciseness of GPS.
- ▶ If you use GPS receiver inside buildings, tunnels, or besides any huge objects, the GPS signals might be cut-off or disturbed. Please do not assume the receiver has malfunctioned.
- ▶ This application note provides the necessary guideline to successfully design a system using GPS modules. For detailed module specification, please refer to the corresponding datasheet of GPS module.
- ▶ GPS Module is an electrostatic sensitive device, please don't touch GPS module directly, please follow ESD safety rule when handling.
- ▶ For the first time, it is strongly recommended to bring the device, using GPS module, outdoor with under open sky for at least 10 to 15 minutes to ensure 3D position fix and almanac update.

This document is the exclusive property of AscenKorea Inc. and should not be distributed, reproduced, into any other format without prior permission of AscenKorea Inc. Specifications subject to change without prior notice.

AscenKorea Inc.

Rm. 710, 7F, Halla Sigma Valley B/D, Gasandigital 2Ro 53, Geumcheon-gu, Seoul, Korea

Tel: +82 02 858 7810 Fax: +82 02 858 7813/ [www.AscenKorea.com](http://www.AscenKorea.com) /[sales@ascen.co.kr](mailto:sales@ascen.co.kr)

copyright © AscenKorea Inc. All right reserved





## Technical Support

---

If you have any technical problems or cannot find the required information in our documents, please feel free to contact us for technical support. Below is a list of information which you can provide that will be very useful to us in determining source of the problem and the necessary solution:

1. Your company name and website
2. Description about application and system
3. GPS module type
4. GPS firmware version
5. Description of the question or problems encountered, together with pictures or videos files
  - Test setup
  - The problem or issue shown in pictures

Technical contact information: [sales@ascen.co.kr](mailto:sales@ascen.co.kr)



## 1. Introduction

---

AscenKorea has a variety of GPS modules designed for many different applications. The modules are classified into two major families: AKMLx and its successor the AKMxx family, or the AKSx and its successor the AKSxx family (where x denotes the model number). The major difference between these two families is the inclusion of smart patch antenna. AKS come with the ceramic antenna, while AKM do not. These GPS modules provide a complete GPS solution that excels in position, speed, and accuracy performances as well as high in sensitivity and tracking capabilities in urban environment. The GPS module are powered by MediaTek Inc. GPS chipset, the world's leading digital media solution provider and largest fab-less IC Company in Korea. AscenKorea's GPS solutions are suitable for assortment of devices, even small-form-factor ones.

## 2. General Rules for Design-in

---

In order to obtain good GPS performances, there are some rules which require attentions for using GPS module:

In order to obtain good GPS performances, there are some rules which require attentions for using GPS module:

### 2.1 Circuit Design

#### 2.1.1 Power supply Vcc

It is necessary to provide a clean and stable power supply for our GPS module in order to obtain good performances (Ex: TTFF). **Unstable power source will have a significant negative impact on the GPS performance. To achieve this, the Vcc ripple must be controlled under 50mVpp.** In addition, there are also some important suggestions for main power circuit design:

- ◆ Add ferrite bead, power choke or low pass filter for power noise reduction
- ◆ Use linear regulator for voltage regulation
- ◆ Use enough decoupling capacitors for stable voltage due to current variation.

## 2.1.2 VBACKUP (BACKUP\_PWR) backup battery

The backup power is necessary for all modules to work normally.

Backup power is used for keeping RTC running and navigation data after the main power was turn off. For most cases with backup power, the GPS module can have a shorter TTFF, Time to First Fix, or hot start.

It is recommended to connect the module via VBACKUP to a sustained power source (ex: Li-Ion rechargeable coin battery) for backup power. There are several ways to maintain the backup power, such as Li battery, super capacitor or just wired to VCC. See figure 1, 2 and 3 for reference. About super capacitor reference design, please refer to appendix.

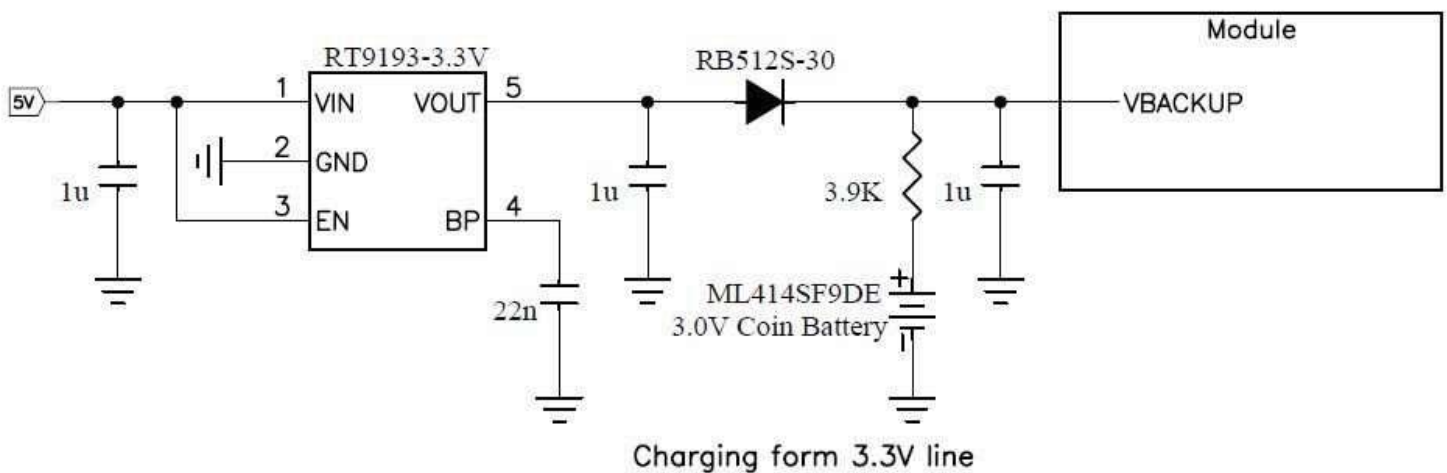

Figure F1, Backup power using regulator for GPS module



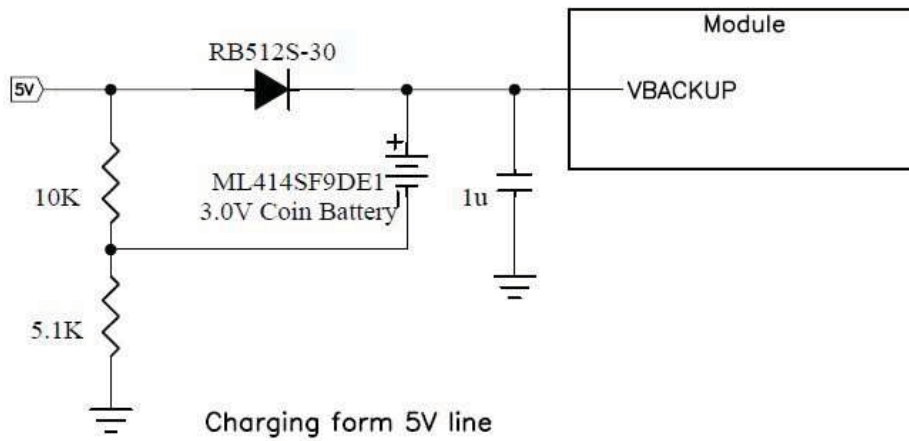

Figure F2, Backup power using voltage divider for GPS module

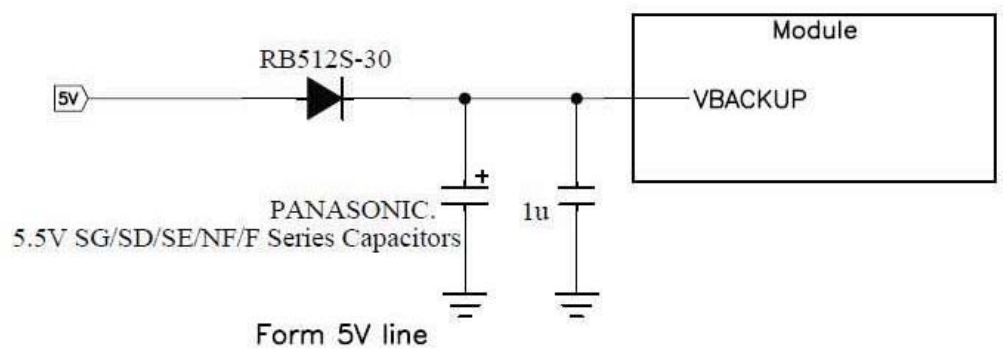
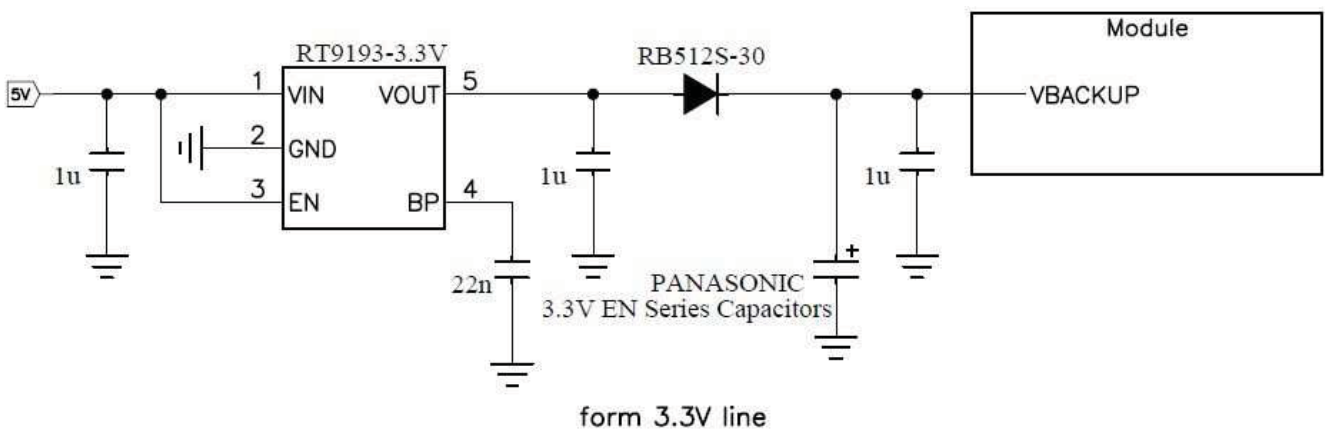

Figure F3, Backup power using regulator with super capacitor

This document is the exclusive property of AscenKorea Inc. and should not be distributed, reproduced, into any other format without prior permission of AscenKorea Inc. Specifications subject to change without prior notice.



## 2.1.3 UART 0 (RX/TX) –Serial Interface

UART is the default interface, the logic, which is TTL level, supports transfer baud rate ranging from 4800 bps to 115200 bps. If RS232 logic-level is needed for any particular application, then the use of level shifter is necessary. Please leave RX open if it is not used as there is an internal pull-up to VCC. Please don't use an external pull-up to prevent unexpected current draw. Please refer to "Appendix III: UART to RS232 Interface" for more information on designing RS232 logic for UART.

Notice:

Please don't connect diode(s) to RX/TX as it will lower signal driving capability which might adversely affect RX/TX signal level (ex. no data output).

## 2.1.4 GND-Ground

Make sure all GND pins of module are linked to a good ground connection.



## 2.1.5 Antenna Design

GPS antenna is a receiving device to acquire week GPS signal from sky. Popular solution would be ceramic patch antenna due to its small form factor with low cost. There are two types of antennas, passive and active. Passive antenna is with solely antenna itself. Active antenna is with LNA to have high gain with the cost of current supply.

Antenna can be chosen according to radiation efficiency, radiation pattern, gain, bandwidth, form factor and cost. Make sure the ground plane is sufficient for the antenna to operate with acceptable performance. And place the matching circuit between antenna and GPS module to compensate the frequency shift due to PCB layout.

To optimize the reception performance under an unfavorable operation environment with noisy sources, please consider the use of an additional SAW filter as a possible solution

- ◆ The total noise figure, NF, must be under 1.5dB.
- ◆ Make sure the antenna is not placed closely to the noisy portion of the whole circuit design.

For the noise rejection of out-of-band, make sure the antenna do NOT have oscillation frequency except the L1 band, 1575.42MHz. For example:

- ✓ 1575.42MHz - main frequency source form not GPS source
- ✓ 525.14MHz - frequency source (  $525.14 \times 3 = 1575.42\text{MHz}$  )
- ✓ 315.084MHz - frequency (  $315.084 \times 5 = 1575.42\text{MHz}$  )
- ✓ 4.092MHz - GPS intermediate frequency



Please also pay special attention to the design of power supply for the external active GPS antennas as they vary between different GPS module models.

- For some GPS modules (ex. AKS6E, AKSU1LP), the DC voltage for the active antenna is provided internally through the same pin as external antenna input pin (EX\_ANT), or through two different pins (ex. AKML1). [Type 1]
- For some models (ex. AKSL3), the power supply for the active antenna needs to be externally provided and is connected to a designated pin (VANT) located on the module, where the DC voltage for the active antenna is outputted from the external antenna input pin. [Type 2]
- Some (ex. AKMU1), the power supply needs to be externally provided and is connected directly to the active antenna. [Type 3]
- AKMU5LP has a unique “Antenna Advisor” System that can be enabled with a additional resistor. Please see reference design for more details. [Type 4]
- AKMU5J comes with special GPS jammer detect feature called “Anti-JACK™” and Antenna Advisor System that requires special attention, please refer to AKMU5J data sheet for more details. [Type 5]

Module	AKS4	AKS6E	AKML1	AKML3	AKMU1	AKS U1LP	AKM U5LP	AKMU5J
Type 1		✓	✓			✓		
Type 2	✓			✓				
Type 3					✓			
Type 4							✓	
Type 5								✓

This document is the exclusive property of AscenKorea Inc. and should not be distributed, reproduced, into any other format without prior permission of AscenKorea Inc. Specifications subject to change without prior notice.



## 2.1.6 1PPS Signal

(Applicable to modules with 1PPS support)

1PPS signal is an output pulse signal useful for timing application, its electronic characteristic are listed below:

Low Voltage level: 0~0.4V, High Voltage level: 2.8~3.1V  
Source current: 14 mA, Sink current 14 mA

Notice:

Depending on user's application, LED + resistor can be directly used with the 1PPS pin without the need of an external buffer. Please note the reference resistor value is 330 ohm.

Please refer to Appendix V for more information on 1PPS signal transmission.

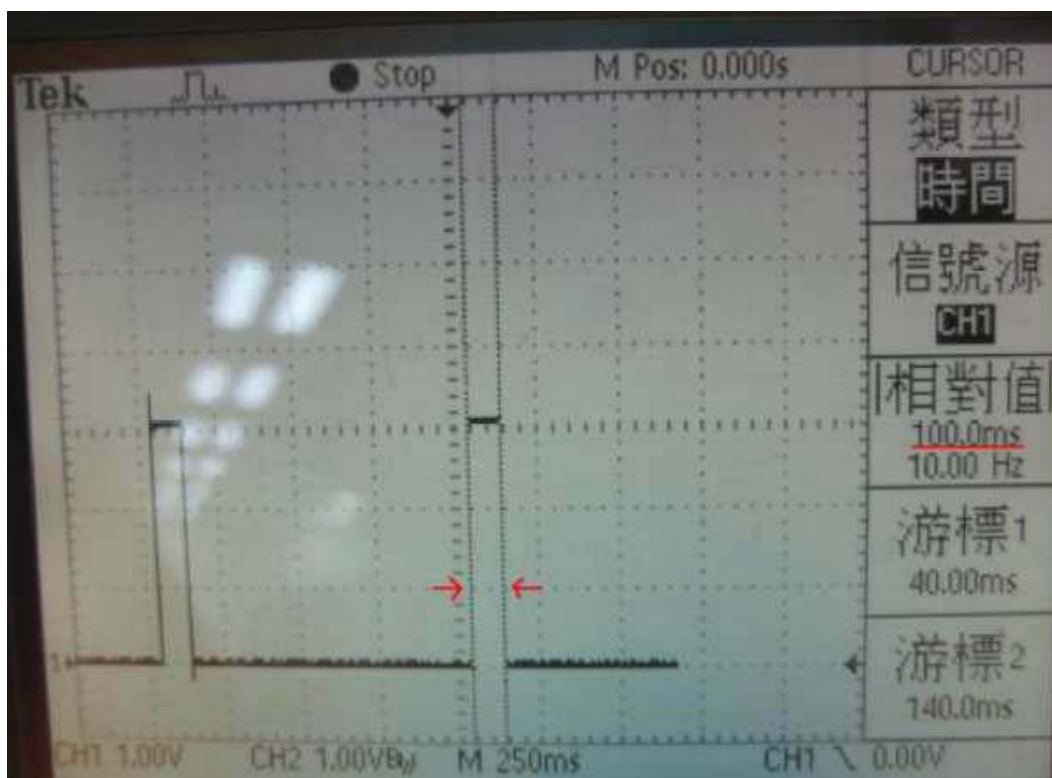

Figure 2.1.6, 1PPS signal and its pulse width with 100ms duration

This document is the exclusive property of AscenKorea Inc. and should not be distributed, reproduced, into any other format without prior permission of AscenKorea Inc. Specifications subject to change without prior notice.

AscenKorea Inc.

Rm. 710, 7F, Halla Sigma Valley B/D, Gasandigital 2Ro 53, Geumcheon-gu, Seoul, Korea

Tel: +82 02 858 7810 Fax: +82 02 858 7813/ www.AscenKorea.com /sales@ascen.co.kr

copyright © AscenKorea Inc. All right reserved



## 2.1.7 Design Restriction

Please keep out of traces and via under the AKS6X/AKSU1LP GPS module to avoid any interferences affecting the antenna pin located at the bottom of the PCB board. (Module AKS6X is used as an example for the figures below)

### Note.

Place one hole (diameter =3.0mm) under this module as part of the antenna pad.

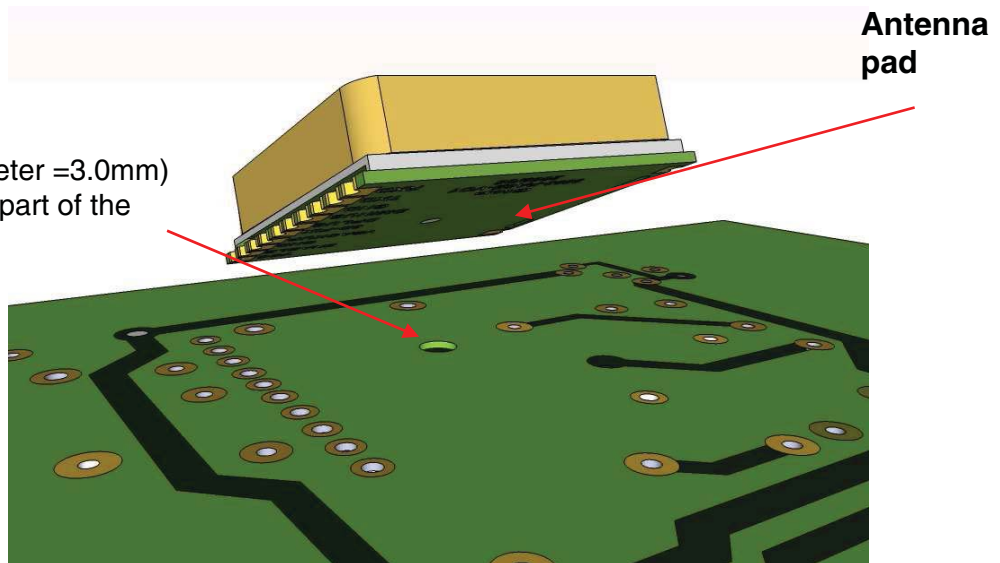

### Note.

If the hole can't be placed on PCB, please don't let any trace and vias pass the area.

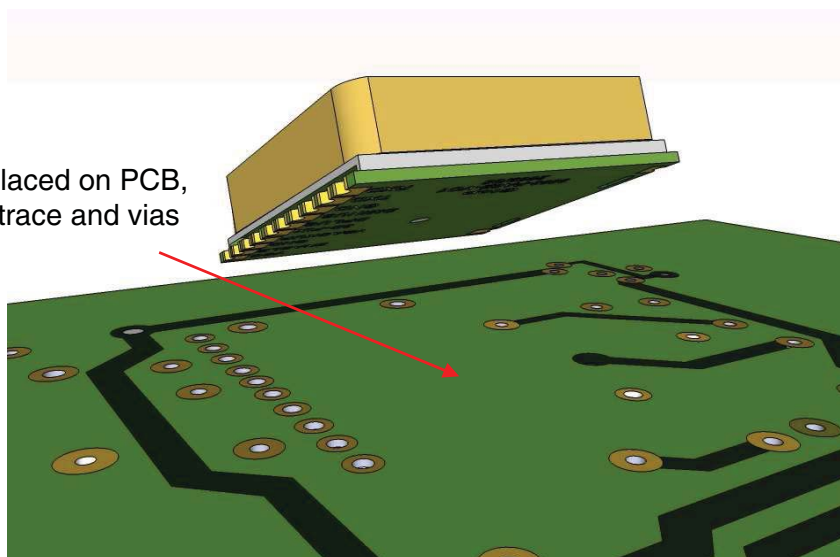

This document is the exclusive property of AscenKorea Inc. and should not be distributed, reproduced, into any other format without prior permission of AscenKorea Inc. Specifications subject to change without prior notice.



## 2.2 Layout Guideline

Please follow the layout criteria to design a system using GPS module.

### 2.2.1 Clearance

It is better to place GPS module higher than other circuitry for better reception.  
There is only patch antenna on top layer, but other components place on bottom layer



### 2.2.2 Placement

- Place the decoupling capacitors close to GPS module
- Place the damping resistors close to GPS module
- Do not place GPS module close to high-speed digital processing circuitry
- Do not place GPS module close to high-current switching power circuitry
- Do not place GPS module close to clock sources circuitry
- Do not place patch antenna close to the tall metal object.

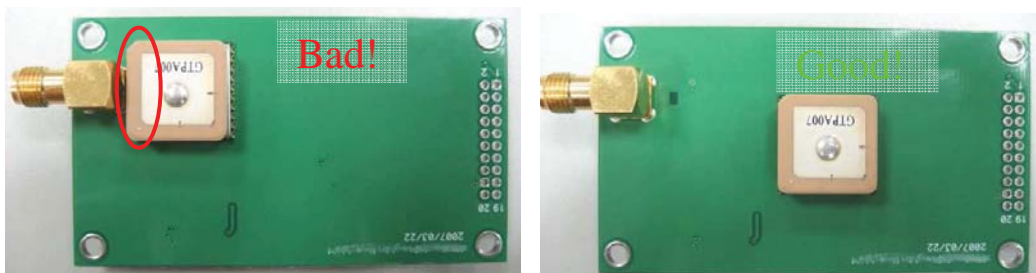

This document is the exclusive property of AscenKorea Inc. and should not be distributed, reproduced, into any other format without prior permission of AscenKorea Inc. Specifications subject to change without prior notice.



### 2.2.3 Trace

Do not trace under the GPS module.

The USB differential signals should be trace close for minimum loop radiation  
RF traces have to execute the 50 ohm impedance control for good sensitivity  
Any right angle turn in trace routing should be accomplished with two 135 degree turn or an arc turn



It is better to have independent trace of power source for any device

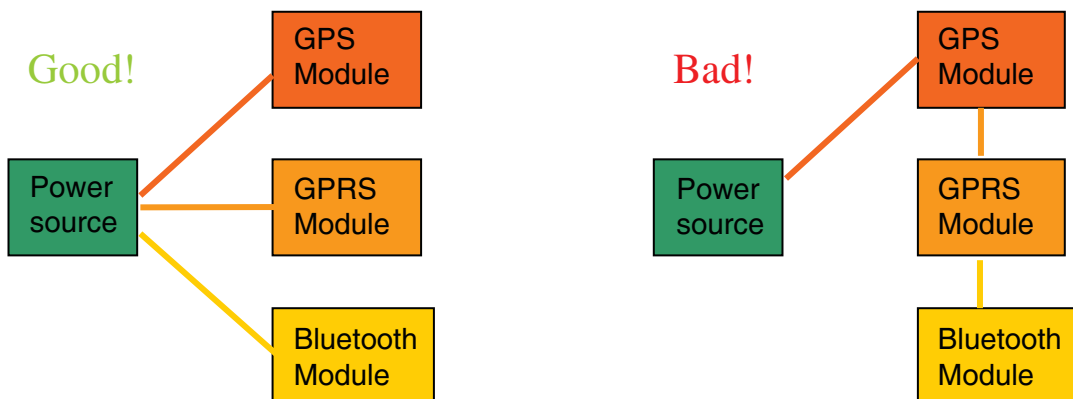

### 2.2.4 Damping Resistors

The purpose of placing damping resistor at the designated I/O ports (Typically the Rx and Tx) of the GPS module is to limit the radiation given out at these points to comply with FCC or CE regulations. Fine tuning the damping resistor is required as the amount of radiation will be dependent on user's application. As a general rule, the longer the layout line is, the higher the radiation will be, and a higher value (ohm) damping resistor is required to keep the radiation level down.

Typically, Damping Resistor under 1000ohm will not affect communication signal quality.

This document is the exclusive property of AscenKorea Inc. and should not be distributed, reproduced, into any other format without prior permission of AscenKorea Inc. Specifications subject to change without prior notice.



## 2.2.5 Ground Segmentation

The separation of ground between GPS module and the rest of the system is recommended to avoid interference. If this is not possible, it is best to follow these typical rules: segmentation of ground between digital and analogue system, high current and low current system, and different radiation systems in general (such as GPS and GPRS).

One way to segment the ground is to place digital and noise component at one corner of the board, while placing analog and quiet components at the opposite corner of the board. Make sure there is no crossing of microstrip or current between the two component sets and grounds of each sets are contacted in one point only.

Another way to do this is to place the two different sets at different layers of the board, while the ground of each layer is contacted in one point only (preferable at border of the board).

## 2.2.6 Ground Plane

Having a ground plane designed for GPS module with built-in passive antenna (such as AKS6B , AKS6E, AKSU1LP ) is crucial as it can enhance the magnetic-field line of the antenna for better GPS signal reception. **It is strongly recommended to have a ground plane designed underneath the GPS module with integrated antenna at top layer.** The GPS reception can be further improved by increasing ground plane size until it reaches the optimum size for GPS reception (performance equal to an external GPS antenna).

The recommended thickness for the ground layer is 0.5 to 1 OZ (0.0175 to 0.035 mm)

It is best to place the ground plane on the top layer of the PCB, directly underneath the GPS module as the figure below shows:

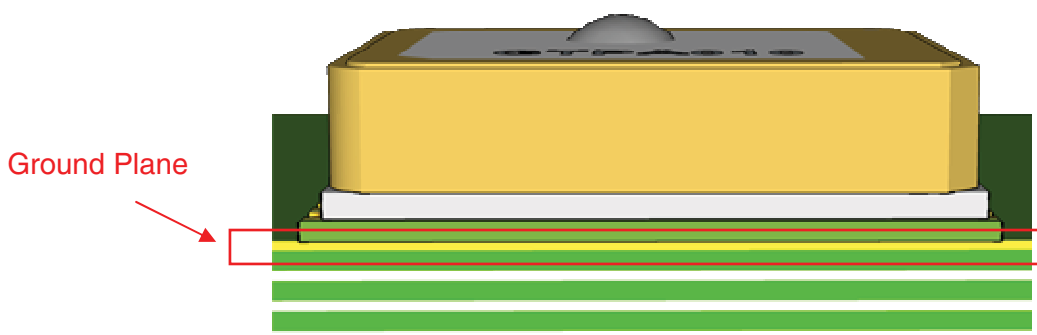

This document is the exclusive property of AscenKorea Inc. and should not be distributed, reproduced, into any other format without prior permission of AscenKorea Inc. Specifications subject to change without prior notice.

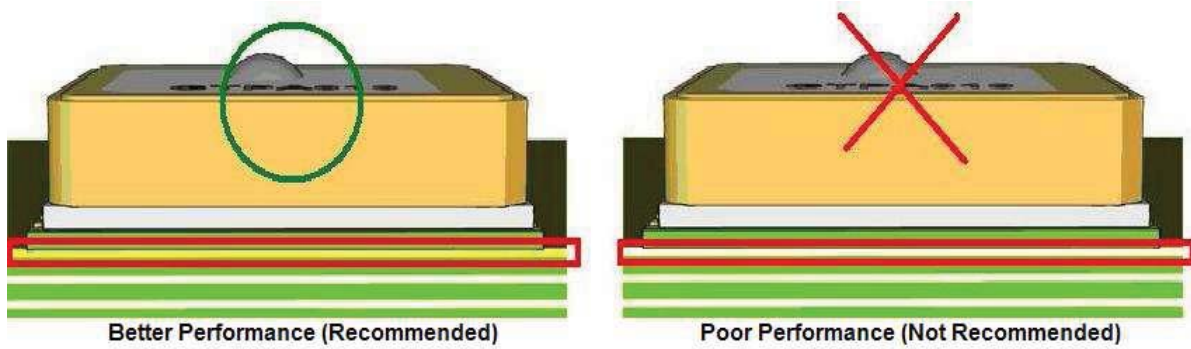

Ground Plane for FR4 Design

Here is a table that shows the ground plane size in relation to C/N value of AKS6 series for reference:

Ground Plane Area (Length x Width) (cm)	Top 4 satellite C/N values (higher the better)
No Ground Plane	45, 44
2.6 x 2.6 (Square)	47, 46, 45, 44
3.6 x 3.6 (Square)	48, 46, 46, 44
4.6 x 4.6 (Square)	47, 47, 46, 46
5.6 x 5.6 (Square)	48, 47, 46, 44
<b>6.6 x 6.6 (Square)*</b>	<b>50, 49, 48, 47</b>
2.4 x 3.6 (Rectangle)	48, 46, 46, 46
5.6 x 3.6 (Rectangle)	48, 46, 46, 46
<b>7.6 x 3.6 (Rectangle)*</b>	<b>49, 49, 48, 48</b>
9.6 x 3.6 (Rectangle)	48, 48, 47, 47

\*C/N performance close to that of an external antenna



## 3. Reference Design and Noise

### 3.1 AKML3

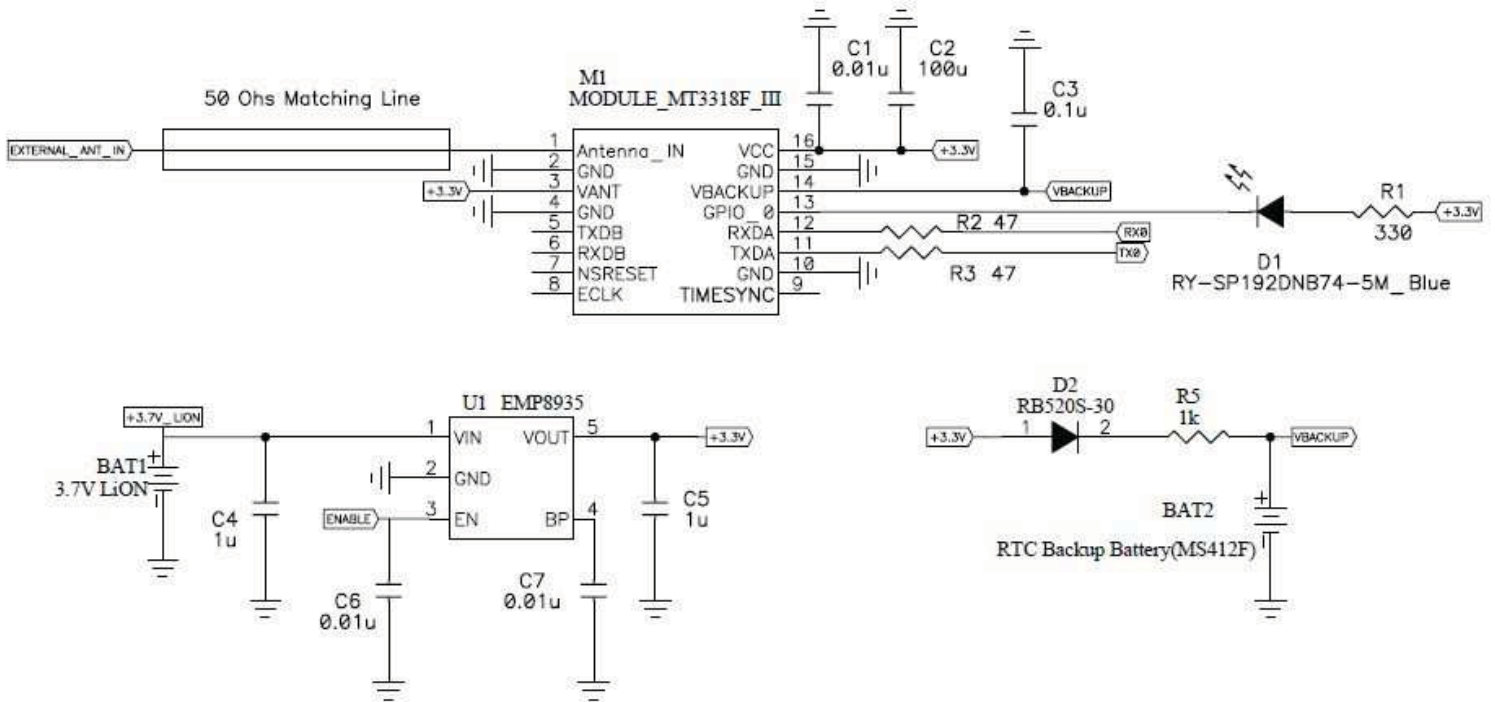

#### Notice about design:

Please note the Vcc and VBAK power source design; it is recommended there are some capacitors and ferrite chip beads.

This document is the exclusive property of AscenKorea Inc. and should not be distributed, reproduced, into any other format without prior permission of AscenKorea Inc. Specifications subject to change without prior notice.



## 3.2 AKS2

### AKS2-C reference design

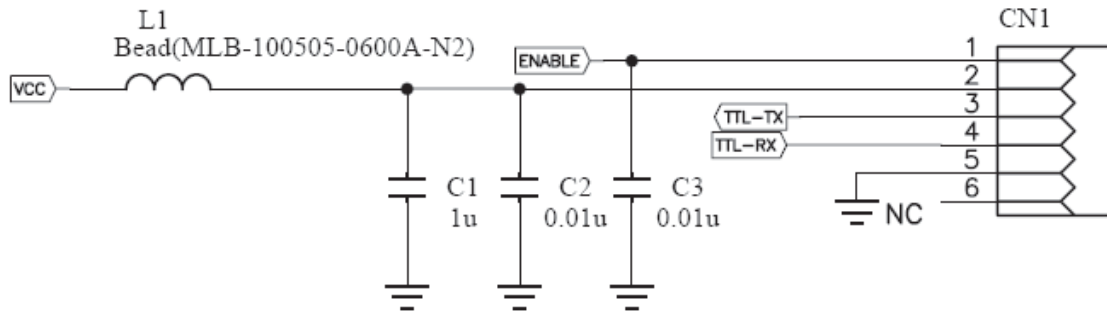

Note: For better filtering L1/C1/C2/C3 components need to be placed Closely CN1

This document is the exclusive property of AscenKorea Inc. and should not be distributed, reproduced, into any other format without prior permission of AscenKorea Inc. Specifications subject to change without prior notice.



## AKS2-P reference design

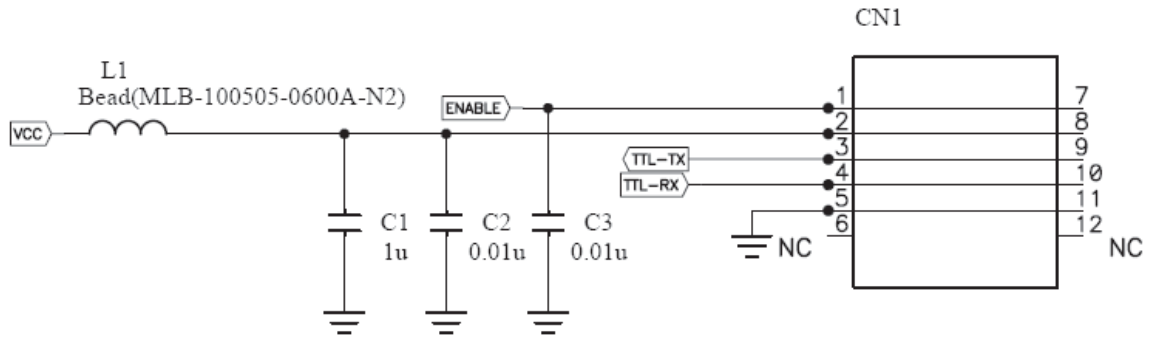

Note: For better filtering L1/C1/C2/C3 components need to be placed Closely CN1

### Notice about design:

Please note the Vcc and VBAK power source design; it is recommended there are some capacitors and ferrite chip beads.

This document is the exclusive property of AscenKorea Inc. and should not be distributed, reproduced, into any other format without prior permission of AscenKorea Inc. Specifications subject to change without prior notice.



### 3.3 AKS4

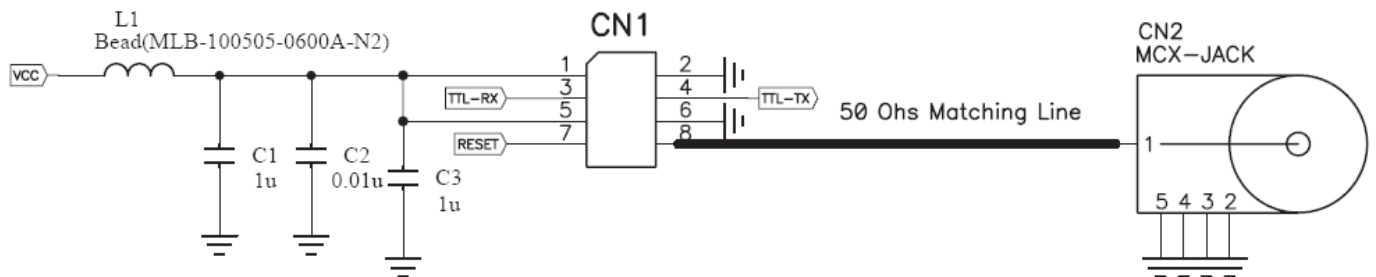

Note: For better filtering L1/C1/C2/C3 components need to be placed Closely CN1

#### Notice about design:

Please note the Vcc and VBAK power source design; it is recommended there are some capacitors and ferrite chip beads.

This document is the exclusive property of AscenKorea Inc. and should not be distributed, reproduced, into any other format without prior permission of AscenKorea Inc. Specifications subject to change without prior notice.

### 3.4 AKS6B/AKS6E

#### AKS6/AKS6B UART reference design

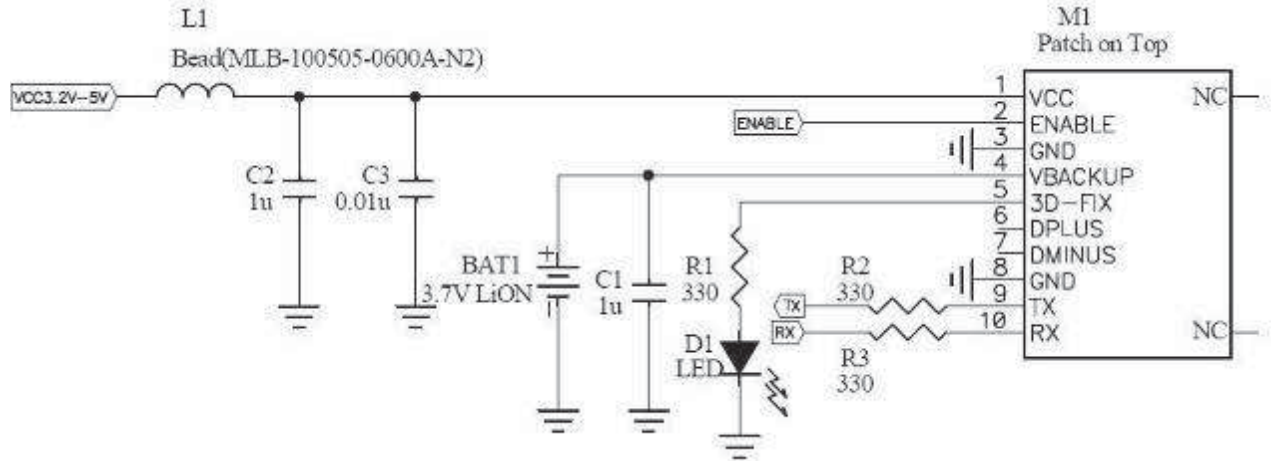

#### AKS6/AKS6B USB reference design

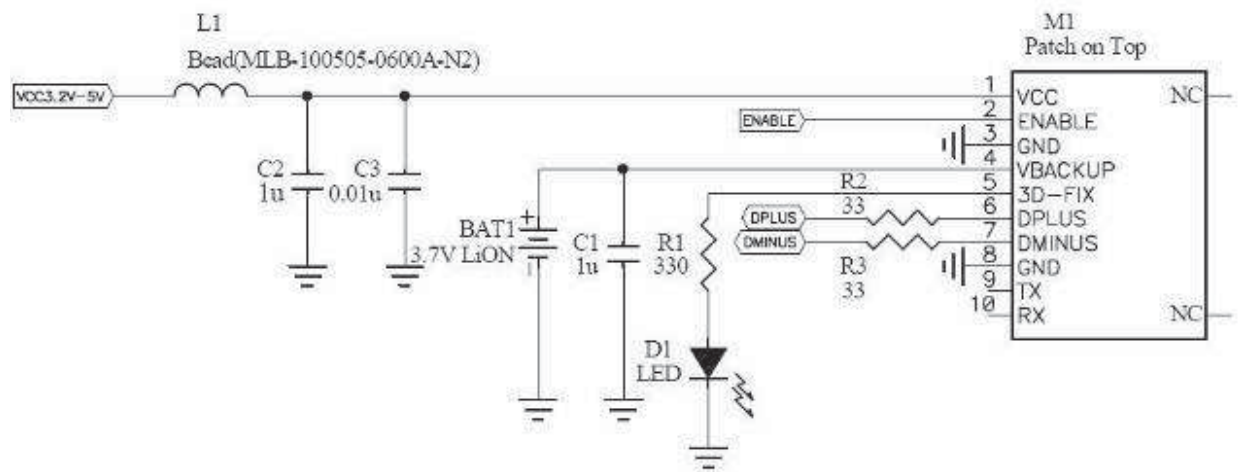

#### AKS6E UART reference design

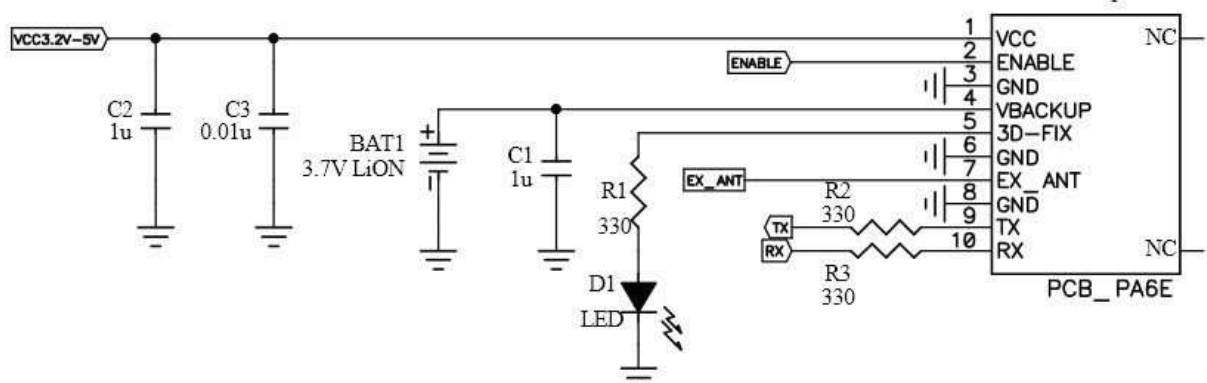

This document is the exclusive property of AscenKorea Inc. and should not be distributed, reproduced, into any other format without prior permission of AscenKorea Inc. Specifications subject to change without prior notice.





## Notice about the design:

### **ENABLE (Pin2)**

Keep open or pull high to Power ON. Pull low to shutdown the module.

Enable (High):  $1.8V \leq V_{enable} \leq VCC$

Disable (Low):  $0V \leq V_{enable} \leq 0.25V$

The pin could be left open if system doesn't want to shut down the power.

### **VBACKUP (Pin4)**

This is the power for GPS chipset to keep RTC running when main power is removed. The voltage should be kept between 2.0V and 4.3V. (Typical : 3.0V)

The pin must be connected for normal operation.

### **3D-FIX (Pin5)**

The 3D-FIX was assigned as fix flag output. If not used, keep floating.

#### 2 Before 2D Fix

The pin should continuously output one-second high-level with one-second low-level signal.

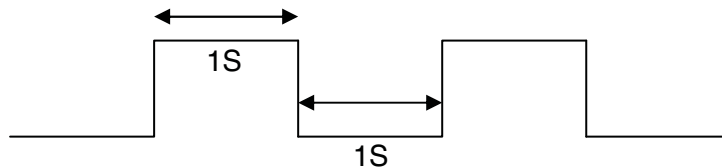

#### 3 After 2D or 3D Fix

The pin should continuously output low-level signal.

Low \_\_\_\_\_

### **DPLUS (Pin6) (for AKS6/AKS6B)**

USB Port DPLUS Signal: if you use the USB interface for connection, please install MT3329 USB VCP driver before you use the module.



## **DMINUS (Pin7) (for AKS6/AKS6B)**

USB Port DMINUS Signal: if you use the USB interface for connection, please install MT3329 USB VCP driver before you use the module.

## **EX\_ANT (Pin7) (only for AKS6E)**

External Antenna input and Output 3.0V power for external antenna.

**The maximum consumption current for the GPS antenna is limited to 30mA.**

When a 3mA or higher current is detected, the IC will acknowledge the external antenna as being present and uses external antenna for reception.

In the event of short circuit occurring at external antenna, the module will limit the drawn current to a safe level.

## 3.5 AKMU1

### ● Patch Antenna Application

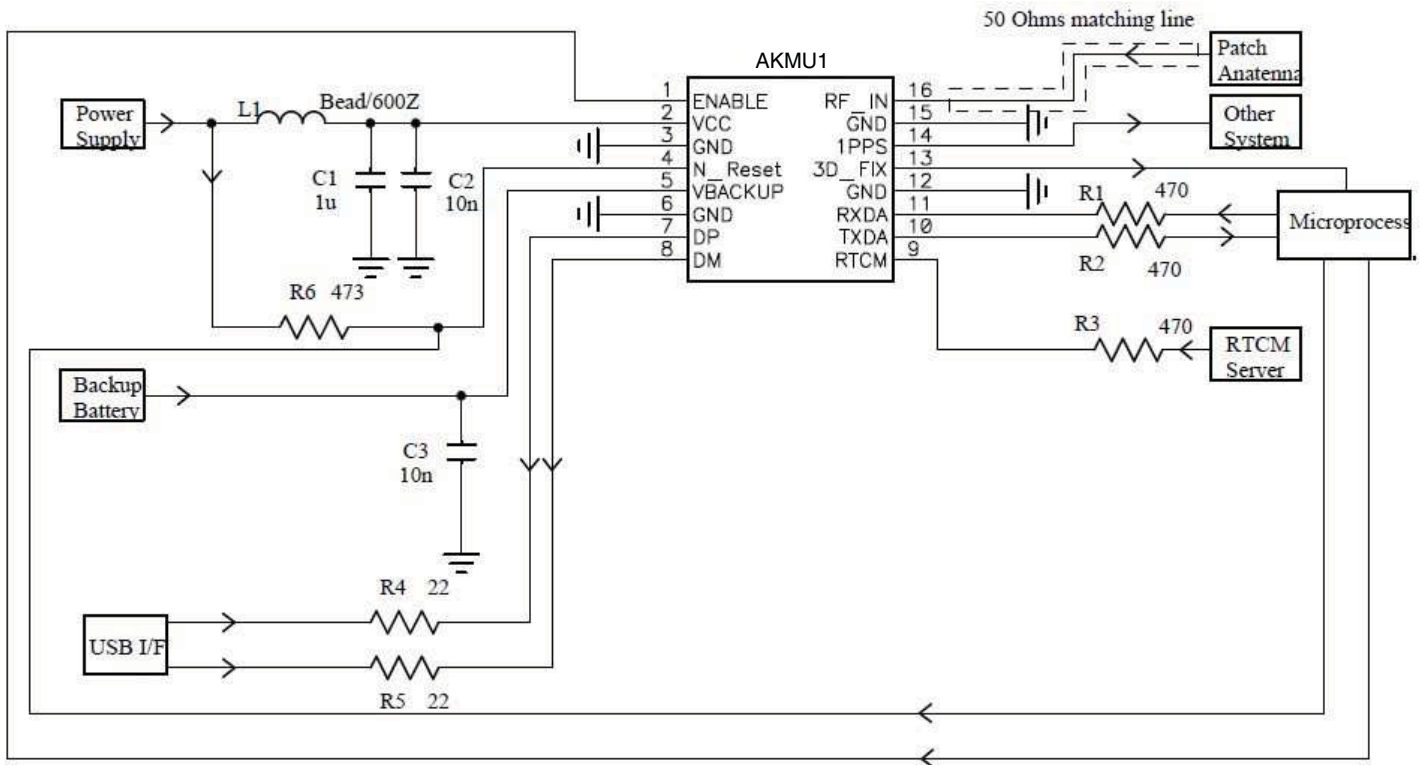

#### Notice:

1. Ferrite bead L1 was add for power noise reduction.
2. C1 and C2 decoupling capacitor should put near module.  
For C1, the value depends on system noise, range 1uF~100uF is reasonable.
3. Damping resistors R1, R2, R3, R4 and R5 should be fine-tuned for system application.

This document is the exclusive property of AscenKorea Inc. and should not be distributed, reproduced, into any other format without prior permission of AscenKorea Inc. Specifications subject to change without prior notice.

● External Antenna Application

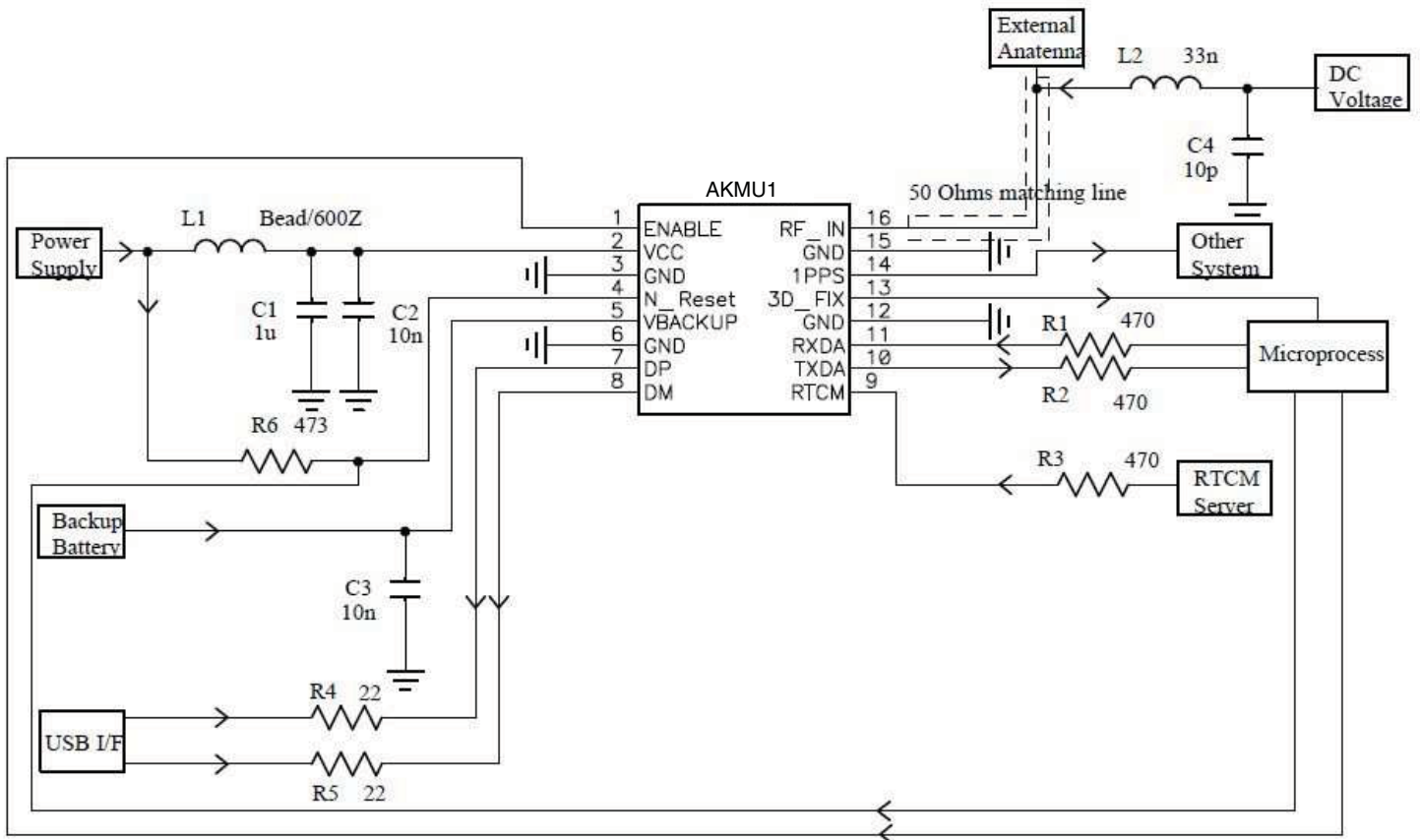

Notice:

1. Ferrite bead L1 was add for power noise reduction.
2. C1 and C2 decoupling capacitor should put near module.  
For C1, the value depends on system noise, range 1uF~100uF is reasonable.
3. Damping resistors R1, R2, R3, R4 and R5 should be fine-tuned for system application.
4. L2 was added for RF Choke.
5. C4 was added for power noise reduction.

RF\_IN (Pin16)

GPS RF signal input. If used to external active antenna, which is the power supply from external DC voltage. The voltage should be kept between 3.0V~10V, **Typical 3.0V**

This document is the exclusive property of AscenKorea Inc. and should not be distributed, reproduced, into any other format without prior permission of AscenKorea Inc. Specifications subject to change without prior notice.

- Antenna (Active) detect circuit reference design

Reference Design

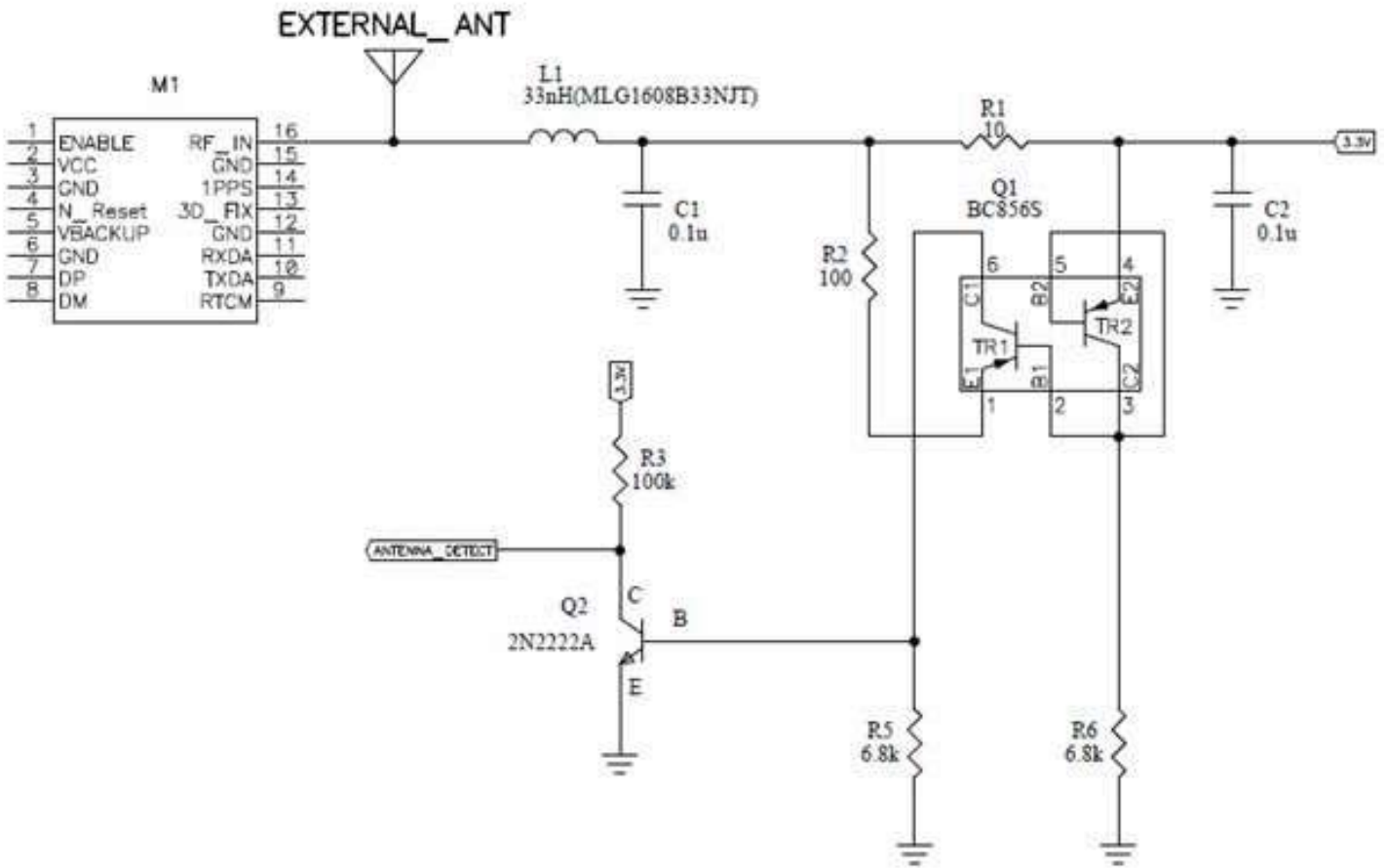

Conditions : When ANTENNA\_DETECT logic  $\cong$  2.0V

R <sub>2</sub> ( $\Omega$ )	EXTERNAL_ANT Current (mA)
100	3.72
200	3.02
220	2.84
330	1.95
390	1.46
470	0.90

Table 1-1

This document is the exclusive property of AscenKorea Inc. and should not be distributed, reproduced, into any other format without prior permission of AscenKorea Inc. Specifications subject to change without prior notice.





### ANTENNA \_ DETECT Logic

ANTENNA _ DETECT Logic	EXTERNAL	Note
1	EXTERNAL Load	The consumption current is higher than specified table 1-1
0	No Load	--

Table 1-2

**Summary:** 470Ω is the recommended value of R<sub>2</sub> when using this schematic. With the external antenna connected (EXTERNAL Load), if the current of EXTENRNAL\_ANT is 0.9 mA or higher, the output logic of ANTENNA\_DETECT will be 1. If the external antenna is not connected (No Load), the output logic will be 0 for ANTENNA\_DETECT (see Table 1-2 for reference).

The output logic of ANTENNA\_DETECT can be adjusted accordingly by changing the value of R<sub>2</sub> to alter for the level of consumption current, please refer to Table 1-1 for more details.

## ● Over Current Protection Circuit

Because of AKMU1/AKMU2P's design, the power supply for external active antenna needs to be provided from an outside source without entering the module. For those interested in protecting the External Antenna from short circuit at the external antenna pin, please add an over current protection circuit as below, and place it in between the power source for the external active antenna and the power input of the external active antenna.

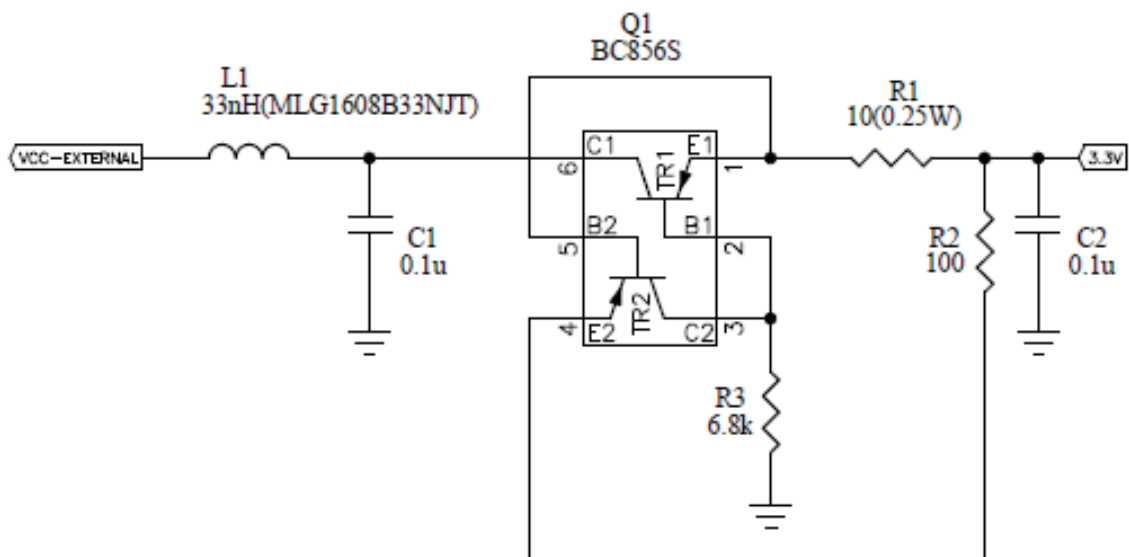

### Note:

#### Normal Action

When the power supply 3.3V input, the TR1 is into saturation region and VCC-EXTERNAL output voltage, TR2 is into cutoff region.

#### Protect Action

If the VCC-EXTERNAL is short to ground and the power supply 3.3V input, the TR1 and TR2 is into active region, therefore limit current is R3 determine.

#### R3 value for Limit Current

R3 is 20K the limit current approximately 30mA.

R3 is 6.8K the limit current approximately 50mA.

R3 is 390 the limit current approximately 100mA.

### 3.6 AKSU1LP

#### USB Interface

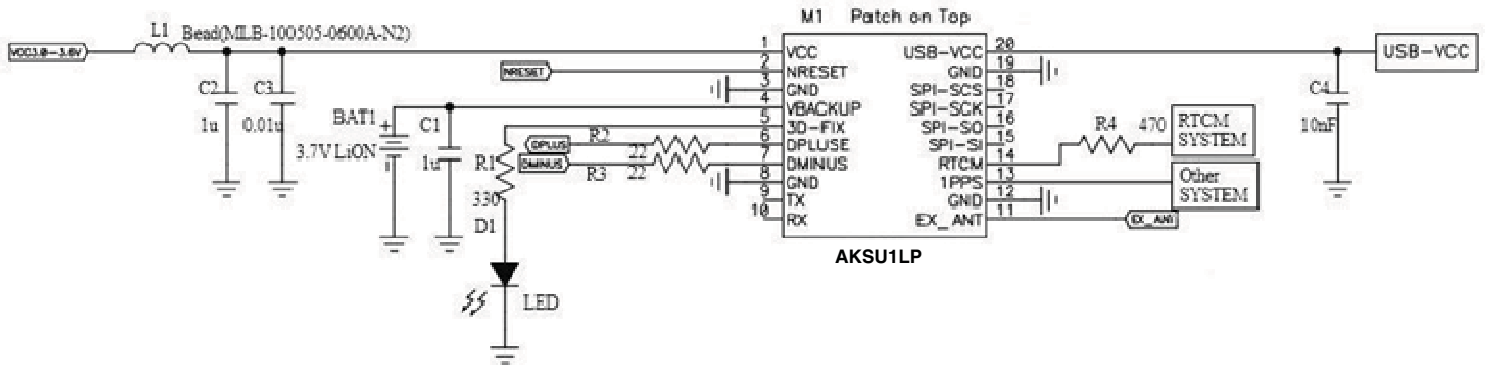

#### UART Interface

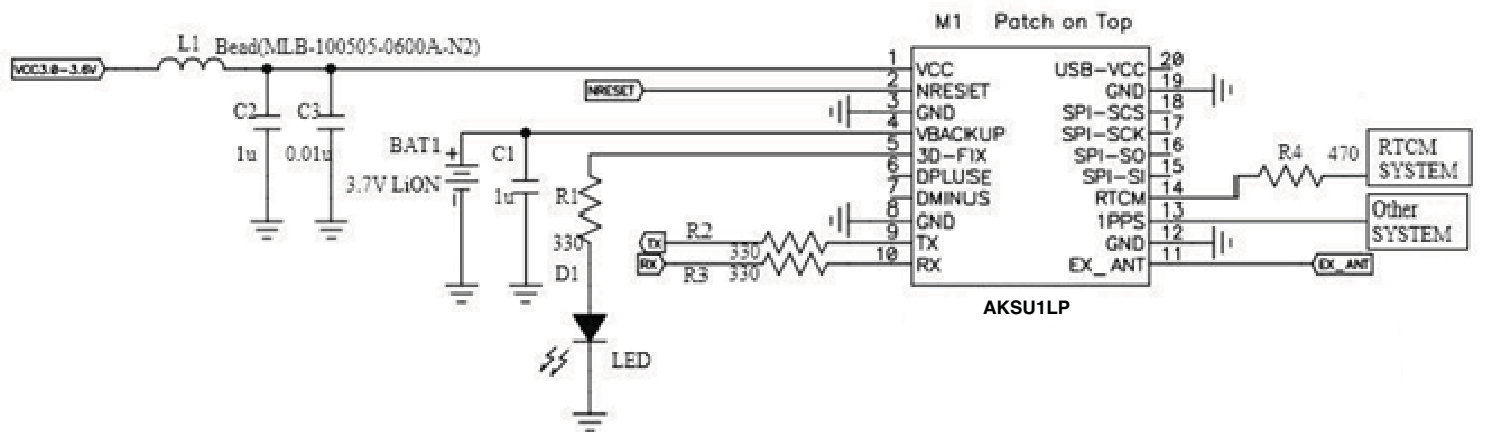

#### Active Antenna Application

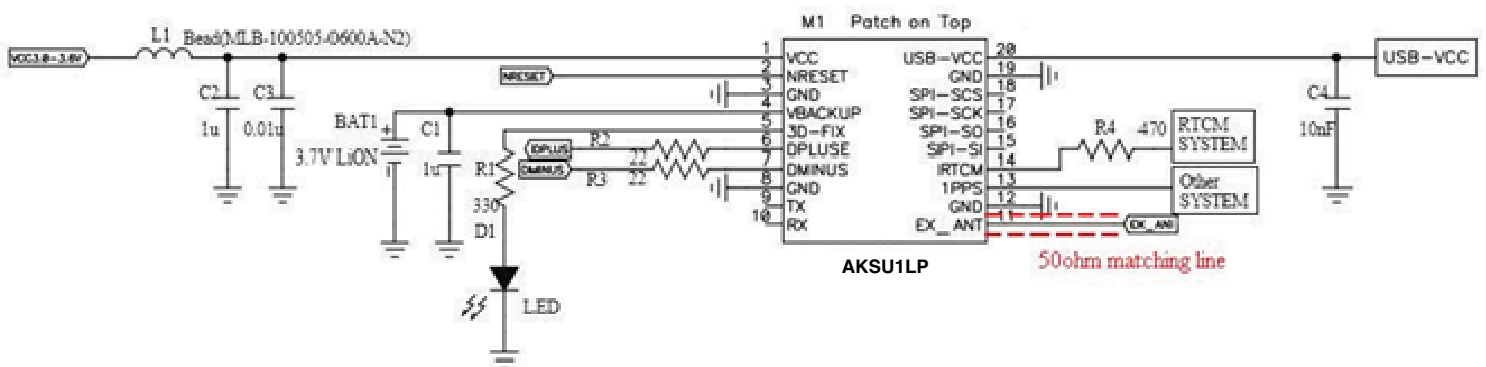

This document is the exclusive property of AscenKorea Inc. and should not be distributed, reproduced, into any other format without prior permission of AscenKorea Inc. Specifications subject to change without prior notice.



### 3.7 AKMU5LP

#### Patch (Passive) Antenna

When using a passive antenna, please connect the antenna directly to Pin16, RF\_IN.

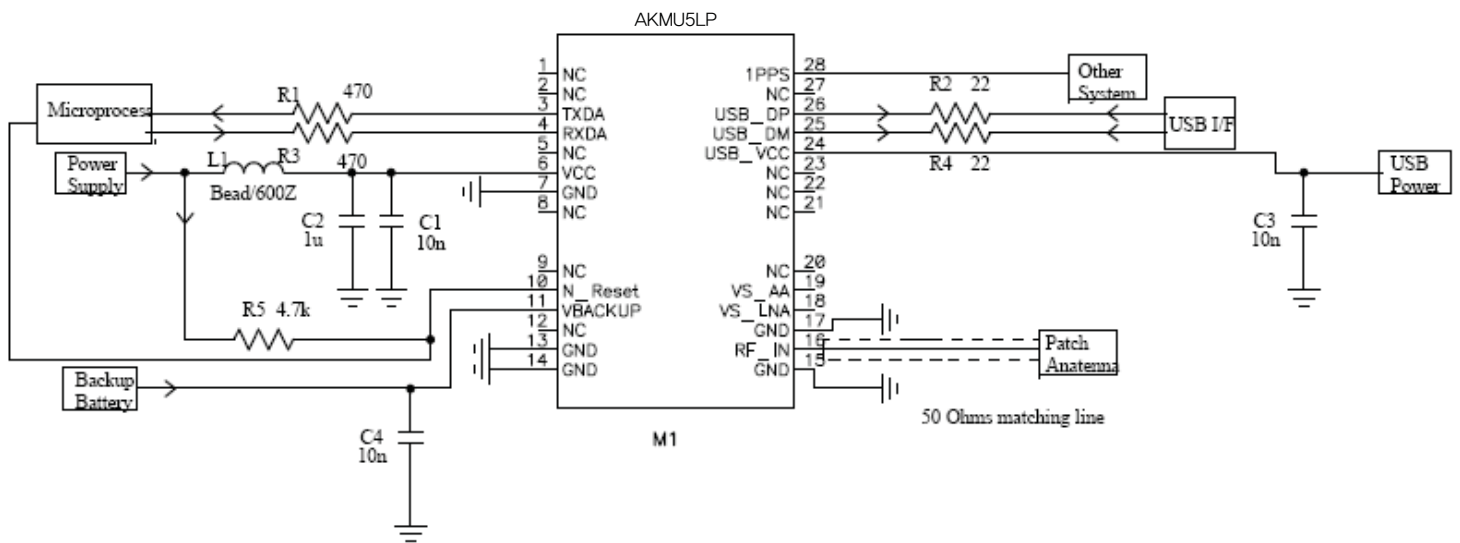

Note:

1. Ferrite bead L1 is added for power noise reduction.
2. C1, C2, C3, and C4, decoupling capacitor should be put near the module.  
For C2, the value chosen depends on the amount of system noise, the range from 1uF to 100uF is reasonable.
3. Damping resistors R1, R2, R3, R4 and R5 could be modified based on system application.

This document is the exclusive property of AscenKorea Inc. and should not be distributed, reproduced, into any other format without prior permission of AscenKorea Inc. Specifications subject to change without prior notice.



## Active Antenna with Antenna Advisor

When using an active antenna, a supply voltage is typically required to drive the internal LNA located inside the active antenna. For majority of the active antenna, the power will be sent on the same coaxial cable used for GPS signal reception through the RF\_IN Pin (Pin 16). For AKMU5LP, this power source is inputted from Pin 19 VS\_AA, which is designed to route the power to RF\_IN Pin.

To power the active antenna through module's own power supply, please add an additional 10 ohm resistor between Pin18 VS\_LNA and Pin19 VS\_AA, which also enables the Antenna Advisor function such as open and short circuit detection and protection.

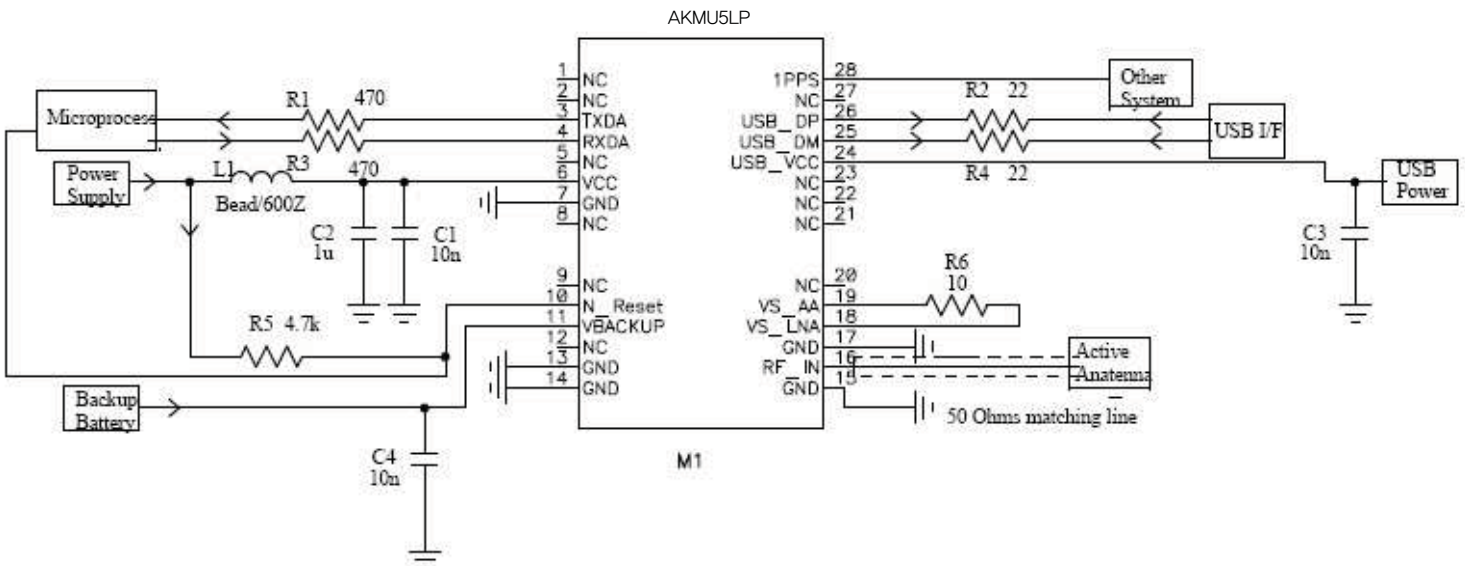

### Note:

1. Ferrite bead L1 is added for power noise reduction.
2. C1, C2, C3, and C4, decoupling capacitor should be put near the module.  
For C2, the value chosen depends on the amount of system noise, the range from 1uF to 100uF is reasonable.
3. Damping resistors R1, R2, R3, R4 and R5 could be modified based on system application.
4. An additional resistor R6 (10ohm) is used to connect Pin 19 VS\_LNA with Pin 18 VS\_AA, which also enables "Antenna Advisor" mechanism.

This document is the exclusive property of AscenKorea Inc. and should not be distributed, reproduced, into any other format without prior permission of AscenKorea Inc. Specifications subject to change without prior notice.





## Active Antenna with External Power Management IC

The reference design is for those who want to use a power management IC to perform external antenna status detection by defining their own behavior. The power IC should supply power to Pin 19 VS\_AA (Range 3.0V to 3.6V, 3mA < current < 30mA), which will be routed to Pin 16 RF\_IN internally, and this in turn will supply the power to the active antenna. (There is an internal inductor between VS\_AA and RF\_IN).

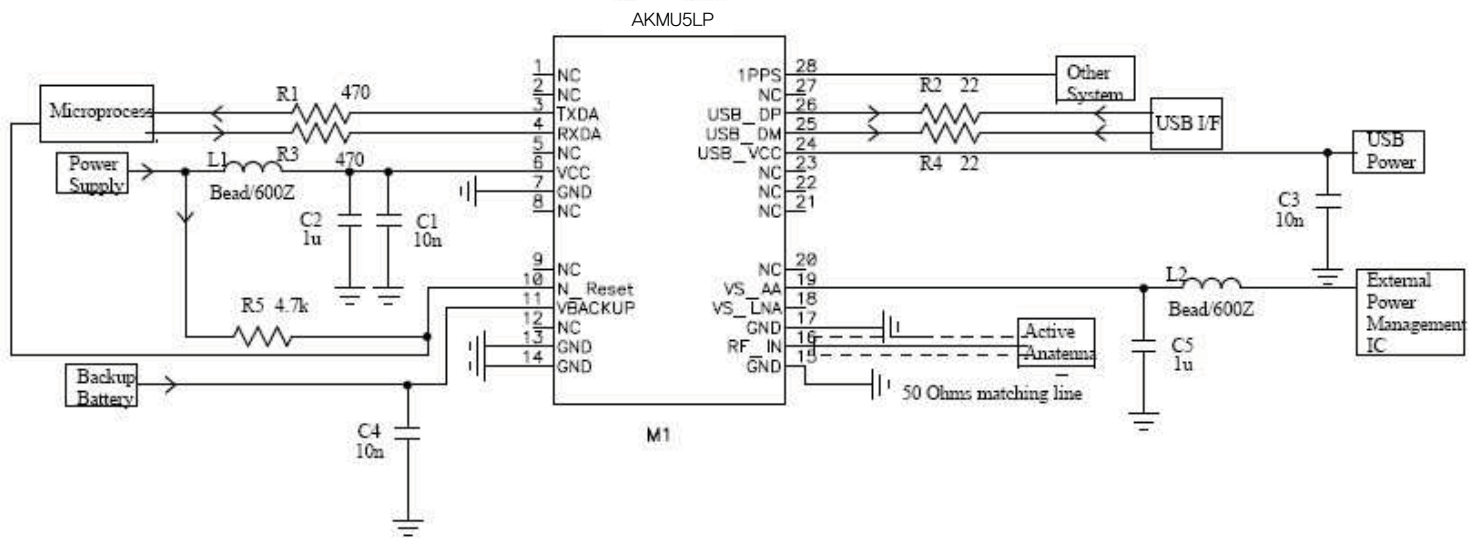

### Note:

1. Ferrite bead L1 and L2 are added for power noise reduction.
2. C1, C2, C3 and C4 decoupling capacitor should be put near the module.  
For C2 and C5 the value chosen depends on the amount of system noise, the range from 1uF to 100uF is reasonable.
3. Damping resistors R1, R2, R3, R4 and R5 could be modified based on system application.
4. "Antenna Advisor" mechanism will be not operational when using this design

This document is the exclusive property of AscenKorea Inc. and should not be distributed, reproduced, into any other format without prior permission of AscenKorea Inc. Specifications subject to change without prior notice.



### 3.7 AKMU5J

#### Patch (Passive) Antenna

When using a passive antenna, please connect the antenna directly to Pin16, RF\_IN.

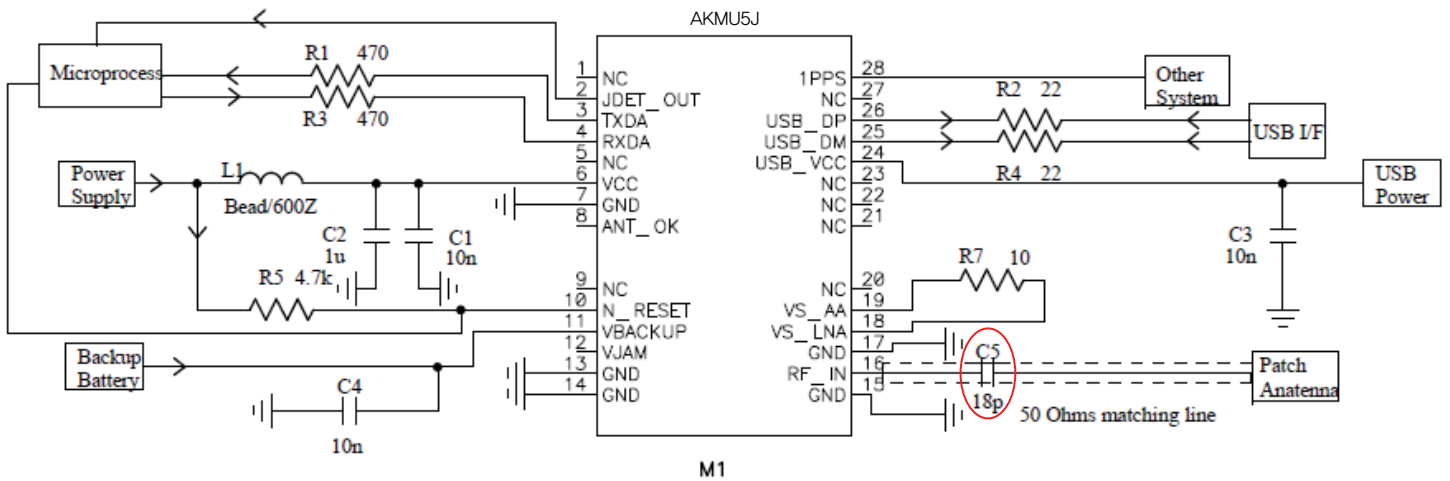

#### Note:



4. The maximum Jammer detection distance: 2m or less (jamming detector @ high sensitivity)
5. It is not recommended to set jamming detector @ low sensitivity setting using patch antenna
6. If you need more support and information on antenna implementation, please directly contact us at sales@ascen.co.kr for further services.
7. Ferrite bead L1 is added for power noise reduction.
8. C5 coupling capacitor should be put near the Antenna.
9. C1, C2, C3 and C4 decoupling capacitor should be put near the module.  
For C2, the value chosen depends on the amount of system noise, the range from 1uF to 100uF is reasonable.
10. Damping resistors R1, R2, R3, R4 and R5 could be modified based on system application.
11. An additional resistor R7 (10ohm) is used to connect Pin 19 VS\_LNA with Pin 18 VS\_AA, which also enables "Antenna Advisor" mechanism.

This document is the exclusive property of AscenKorea Inc. and should not be distributed, reproduced, into any other format without prior permission of AscenKorea Inc. Specifications subject to change without prior notice.

## Patch (Passive) Antenna (additional stage LNA)

**Adding a LNA between Patch Antenna and RF\_IN pin will increase jamming detection distance.**

When using a passive antenna, please connect the antenna directly to Pin16, RF\_IN.

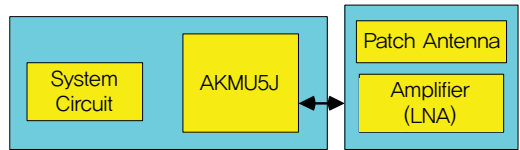
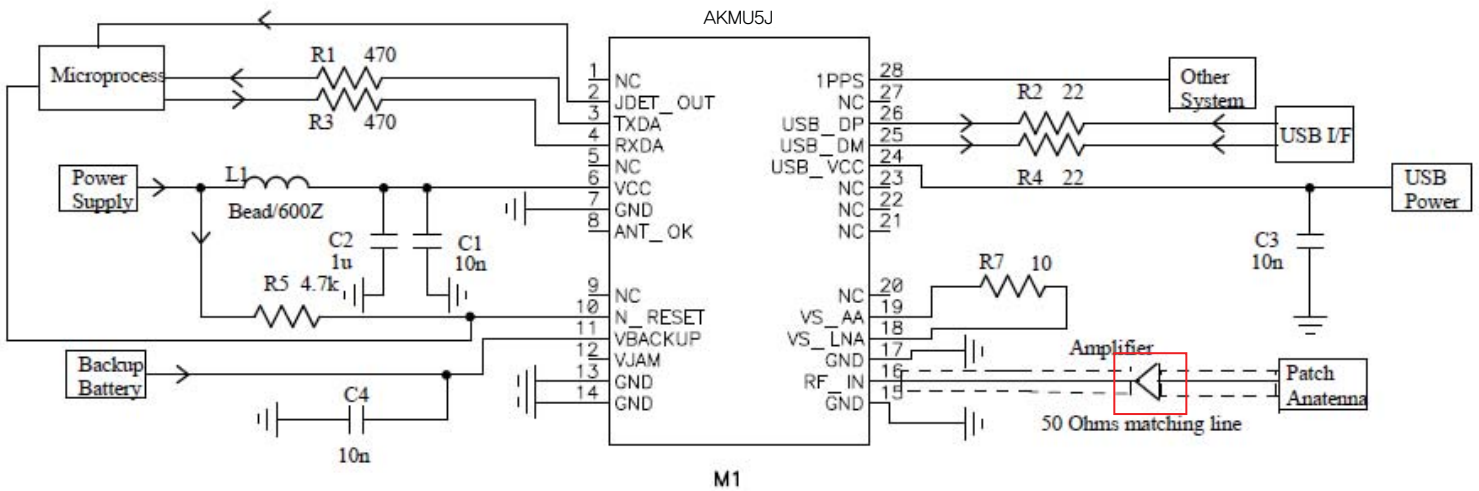

Reference System Block Diagram

Note:

- 1. Addition Amplifier (LNA: Gain <20dB, NF <2dB) between RF\_IN pin and Passive (Patch) Antenna will increase GPS jammer detection distance.  
Recommended Component: JRC NJG1107HB3
- 2. Patch Antenna + LNA must be placed directly before AKMU5J RF-end (RF\_IN). This is to prevent the accidental detection of internal system interference. No additional spacing is required between the antenna and RF\_IN pin.
- 3. Patch Antenna + LNA must not be placed at the opposite side of PCB from AKMU5J
- 4. Power supply for LNA will be directly provided by RF\_IN pin. The voltage range is 3V~3.6V.
- 5. If you need more support and information on antenna implementation, please directly contact us at sales@ascen.co.kr for further services.
- 6. Ferrite bead L1 is added for power noise reduction.
- 7. C5 coupling capacitor should be put near the Antenna.
- 8. C1, C2, C3, and C4 decoupling capacitor should be put near the module.  
For C2, the value chosen depends on the amount of system noise, the range from 1uF to 100uF is reasonable.
- 9. Damping resistors R1, R2, R3, R4 and R5 could be modified based on system application.
- 10. An additional resistor R7 (10ohm) is used to connect Pin 19 VS\_LNA with Pin 18 VS\_AA, which also enables "Antenna Advisor" mechanism.

This document is the exclusive property of AscenKorea Inc. and should not be distributed, reproduced, into any other format without prior permission of AscenKorea Inc. Specifications subject to change without prior notice.



## Active Antenna with Antenna Advisor

When using an active antenna, a supply voltage is typically required to drive the internal LNA located inside the active antenna. For majority of the active antenna, the power will be sent on the same coaxial cable used for GPS signal reception through the RF\_IN Pin (Pin 16). For AKMU5J, this power source is inputted from Pin 19 VS\_AA, which is designed to route the power to RF\_IN Pin.

To power the active antenna through module's own power supply, please add an additional 10 ohm resistor between Pin18 VS\_LNA and Pin19 VS\_AA, which also enables the Antenna Advisor function such as open and short circuit detection and protection.

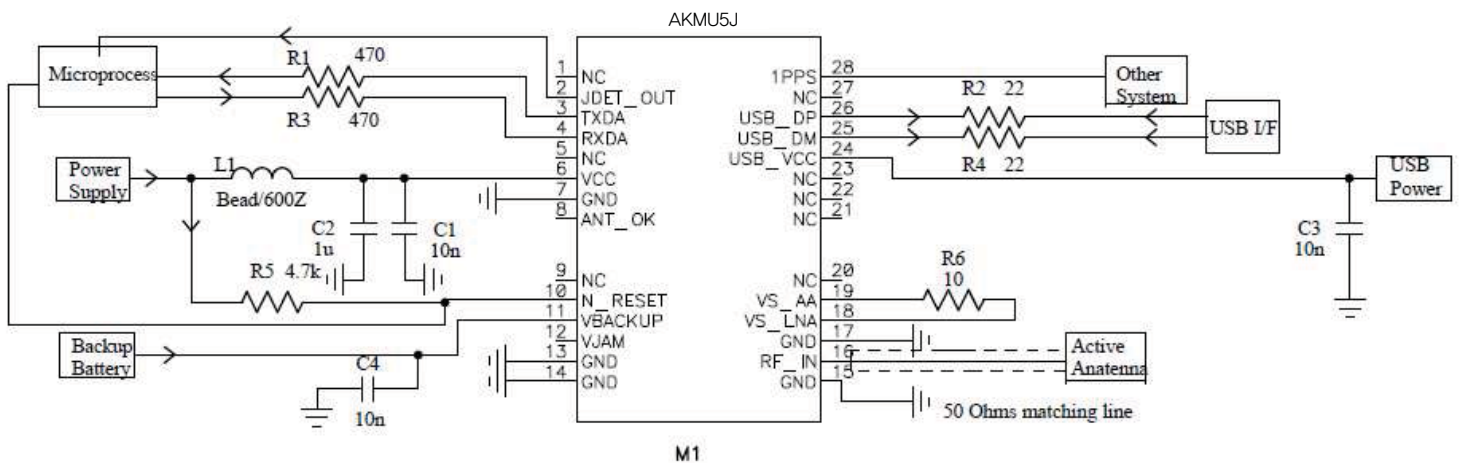

### Note:

5. Please refer to Chapter 4.6 for maximum GPS jammer detection distance.
6. If you need more support and information on antenna implementation, please directly contact us at [sales@ascen.co.kr](mailto:sales@ascen.co.kr) for further services.
7. Ferrite bead L1 is added for power noise reduction.
8. C1, C2, C3 and C4 decoupling capacitor should be put near the module.  
For C2, the value chosen depends on the amount of system noise, the range from 1uF to 100uF is reasonable.
9. Damping resistors R1, R2, R3, R4, and R5 could be modified based on system application.
10. An additional resistor R6 (10ohm) is used to connect Pin 19 VS\_LNA with Pin 18 VS\_AA, which also enables "Antenna Advisor" mechanism.

This document is the exclusive property of AscenKorea Inc. and should not be distributed, reproduced, into any other format without prior permission of AscenKorea Inc. Specifications subject to change without prior notice.

AscenKorea Inc.

Rm. 710, 7F, Halla Sigma Valley B/D, Gasandigital 2Ro 53, Geumcheon-gu, Seoul, Korea

Tel: +82 02 858 7810 Fax: +82 02 858 7813/ [www.AscenKorea.com](http://www.AscenKorea.com) /[sales@ascen.co.kr](mailto:sales@ascen.co.kr)

copyright © AscenKorea Inc. All right reserved



## Active Antenna with External Power Management IC

The reference design is for those who want to use a power management IC to perform external antenna status detection by defining their own behavior. The power IC should supply power to Pin 19 VS\_AA (Range 3.0V to 3.6V, 3mA < current < 30mA), which will be routed to Pin 16 RF\_IN internally, and this in turn will supply the power to the active antenna. (There is an internal inductor between VS\_AA and RF\_IN).

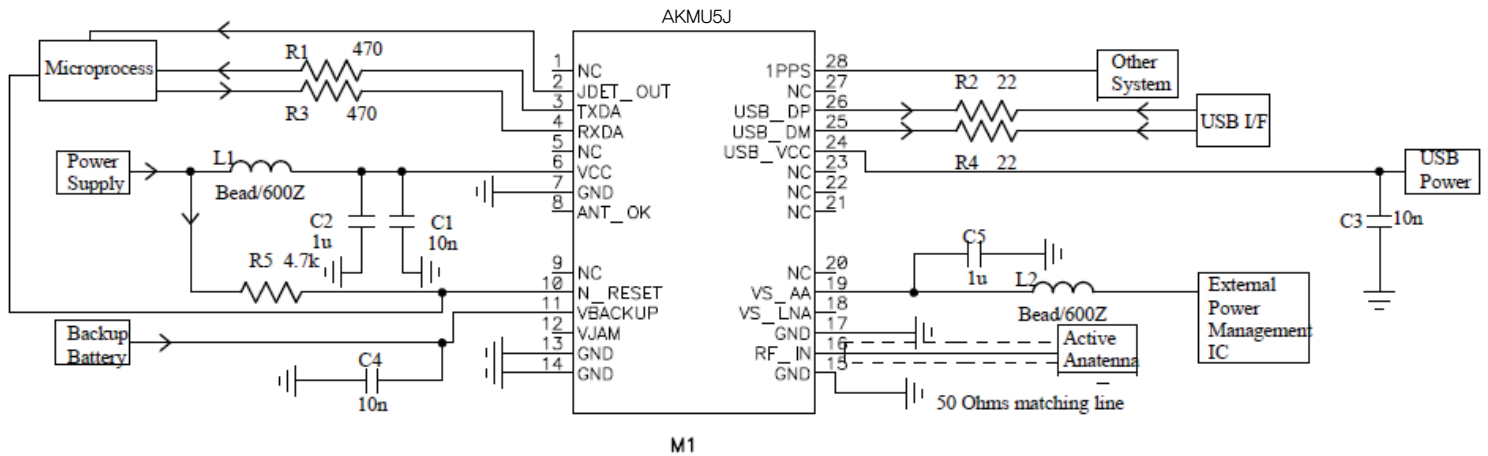

### Note:

5. Please refer to Chapter 4.6 for maximum GPS jammer detection distance.
6. If you need more support and information on antenna implementation, please directly contact us at sales@ascen.co.kr for further services.
7. Ferrite bead L1 and L2 are added for power noise reduction.
8. C1, C2, C3, C4 and C5 decoupling capacitor should be put near the module. For C2 and C5 the value chosen depends on the amount of system noise, the range from 1uF to 100uF is reasonable.
9. Damping resistors R1, R2, R3, R4 and R5 could be modified based on system application.
10. "Antenna Advisor" mechanism will be not operational when using this design.

This document is the exclusive property of AscenKorea Inc. and should not be distributed, reproduced, into any other format without prior permission of AscenKorea Inc. Specifications subject to change without prior notice.





## 4. Thermal Profile for SMD Modules

### (Reference Only)

\*All the information in this sheet should be used only for Pb-free certification.

#### SMT Reflow Soldering Temperature Profile:

Average ramp-up rate (25 ~ 150° C): 3° C/sec. max.

Average ramp-up rate (270° C to peak): 3° C/sec. max.

Preheat: 175 ± 25° C ´ 60 ~ 120 seconds

Temperature maintained above 217° C: 60~150 seconds

Peak temperature: 250 +0/-5° C ´ 20~40 seconds

Ramp-down rate: 6° C/sec. max.

Time 25° C to peak temperature: 8 minutes max.

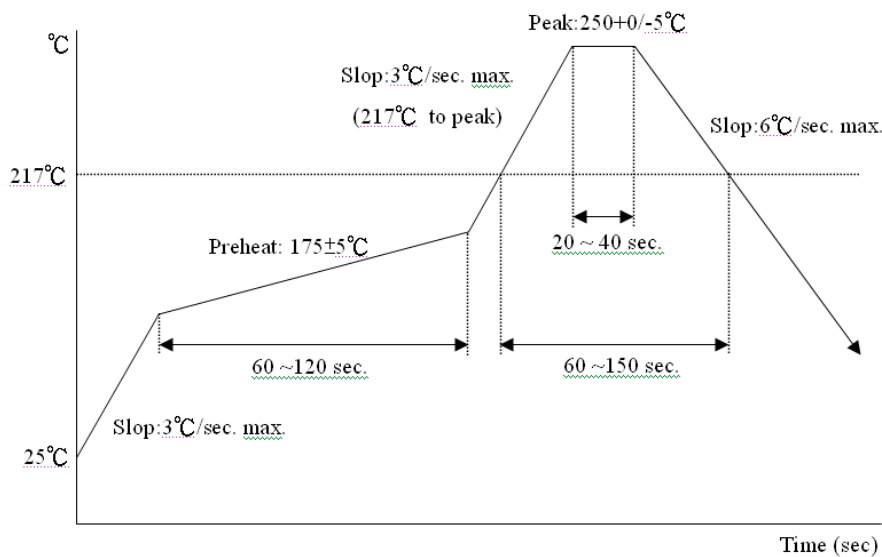

#### SMT Solder Mask:

Please use the dimension of PCB pad as reference and shrink the size by 0.1 to 0.2 mm and use that as layout for paste mask. (For PCB pad layout, please see “Recommended PCB pad layout” on individual GPS module data sheet)

#### Manual Soldering:

Soldering iron: Bit Temperature: Under 380° C

Time: Under 3 second.

This document is the exclusive property of AscenKorea Inc. and should not be distributed, reproduced, into any other format without prior permission of AscenKorea Inc. Specifications subject to change without prior notice.



## 5. Troubleshooting

---

### How to check for the working status of AKS6/AKS6B?

The first thing to check for is the NMEA sentence output through TX by using various application tools. For example: you can use windows default tool – WinXP Hyperterminal, or you can use other GPS application program to check for GPS status.

If there is no NMEA output, this indicates the PA6/PA6B module is currently not working. Please double check your schematic design. Down below we listed some of the possible items to check for your reference:

#### Item 1: VCC (Pin1)

The voltage should be kept between 3.2V to 5.0V. **(Typical : 3.3V)**, Please double-check.

#### Item 2: ENABLE (Pin2)

AKS6/AKS6B module have internal resistor to pull high (to Vcc), the level is Vcc level, please check the enable pin should be kept between 3.2V to 5.0V. **(Typical : 3.3V)**, Please double-check.

#### Item 3: VBACKUP (Pin4)

The voltage should be kept between 2.0V~4.3V. **(Typical : 3.0V)**. If the module has no power for the VBACKUP, the GPS module will not work. It is recommended that a sustain power for VBACUP is supplied to keep RTC time and navigation data, Please double-check



### Item 4: 3D-FIX (Pin5)

If all the measurements are within the specifications, please also measure 3D-FIX (Pin5) signal. Before 2D Fix, the pin should output one-second high-level signal follow with one-second low-level signal.

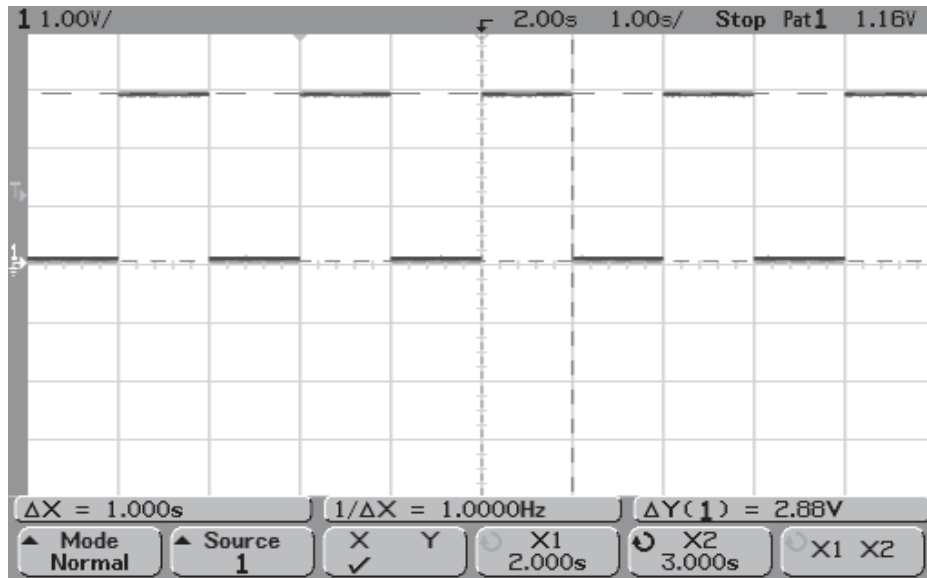

### TXD (Pin9)

The UART transmitter of the module, it outputs the GPS NMEA information for application.

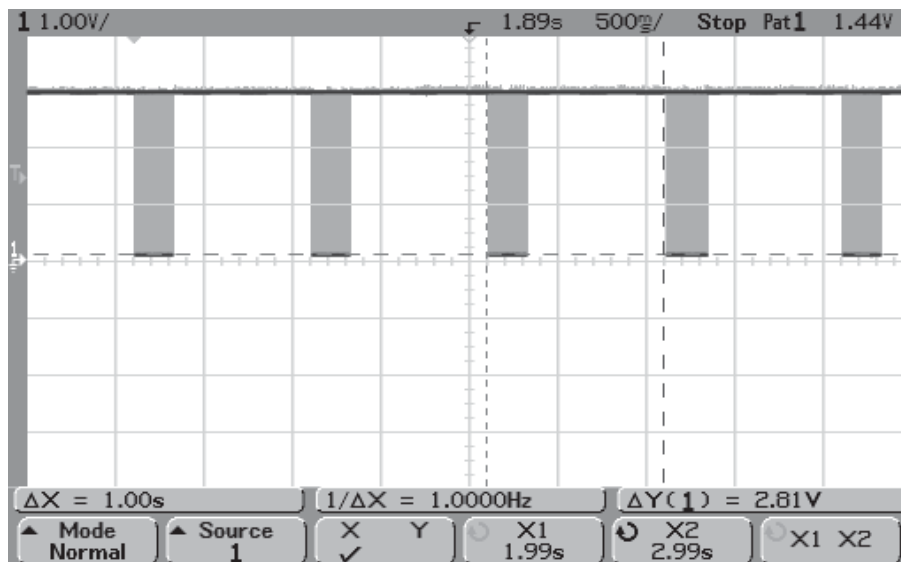

This document is the exclusive property of AscenKorea Inc. and should not be distributed, reproduced, into any other format without prior permission of AscenKorea Inc. Specifications subject to change without prior notice.



## 6. Contact

---

For help or further information, please contact us via the following methods:

### **Ascenkorea Technology Inc.**

**Address:** AscenKorea Inc.

Rm. 710, 7F, Halla Sigma Valley B/D, GasanDigital 2Ro 53, Geumcheon-gu,  
Seoul, Korea

**Tel:** +82 2 858 7810 **Fax:** +82 2 858 7813

**Web Site :** [www.AscenKorea.com](http://www.AscenKorea.com)

**Sales Email:** [sales@ascen.co.kr](mailto:sales@ascen.co.kr)

This document is the exclusive property of AscenKorea Inc. and should not be distributed, reproduced, into any other format without prior permission of AscenKorea Inc. Specifications subject to change without prior notice.

AscenKorea Inc.

Rm. 710, 7F, Halla Sigma Valley B/D, Gasandigital 2Ro 53, Geumcheon-gu, Seoul, Korea

Tel: +82 02 858 7810 Fax: +82 02 858 7813/ [www.AscenKorea.com](http://www.AscenKorea.com) /[sales@ascen.co.kr](mailto:sales@ascen.co.kr)

copyright © AscenKorea Inc. All right reserved

## Appendix I: Super Capacitor Design

### About Super Capacitors

Super capacitors have a useful life-time similar to aluminum electrolytic capacitors. The life of a super capacitors capacitor is largely dependent on the operating temperature, humidity, applied voltage, current and backup time requirements. Therefore, the life of a super capacitor is determined based on the backup time set by the customer.

### How to calculate the backup time

The example below teaches how to calculate the backup time.

$$T = C (V_0 - V_1) / (I + I_L)$$

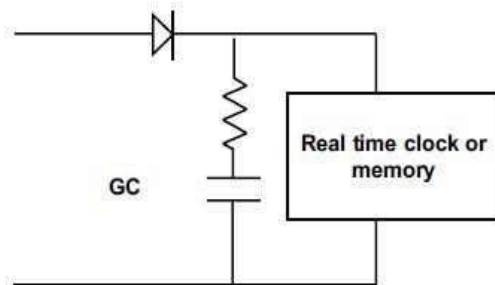

Capacitor's voltage

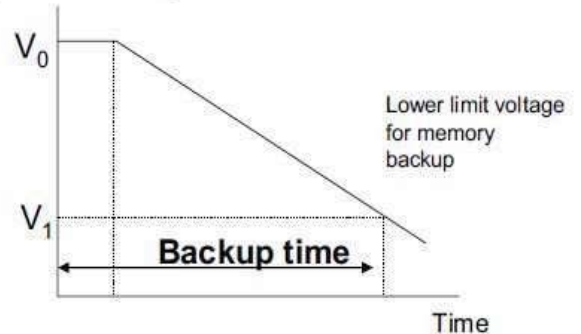

#### Example:

$$V_0 = 2.5V, V_1 = 1.8V, I = 10\mu A, C = 0.2F$$

$$\begin{aligned} T &= 0.2 ( 2.5 - 1.8 ) / ( 10 \text{ e-}6 + 0.2 \times 10^{-6} ) \\ &= 0.14 / 10.2 \times 10^{-6} \\ &= 13,725 \text{ seconds} \\ &= 3.8 \text{ hours} \end{aligned}$$

- T: Backup time (second)
- C: Capacitance of Gold Capacitor (F)
- V<sub>0</sub>: Applied voltage(V)
- V<sub>1</sub>: Lower limit voltage for memory backup(V)
- I: Current during backup(A)
- I<sub>L</sub>: Leakage current(A) about 0.2uA

This document is the exclusive property of AscenKorea Inc. and should not be distributed, reproduced, into any other format without prior permission of AscenKorea Inc. Specifications subject to change without prior notice.



## Appendix II: About 50 ohm Matching Line

We used AppCAD tool for 50 ohm impedance calculation of RF line and made a table for layout reference.

RF line width (W)	PCB FR4 Thickness (H)	Dielectric parameter	Copper Thickness an ounce
1.8mm	1mm	4.6	0.035mm

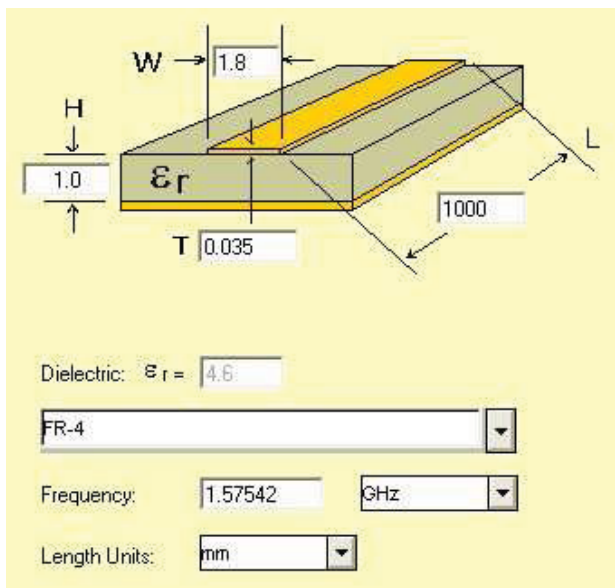

**Notice:**

For multiple-layer layout, designer could place a ground layer in 2nd layer to minimize the trace width in specific PCB (such FR4) and impedance.

For impedance calculation, free software to cal trace width or impedance available.

Please refer to the website for one such software:

<http://web.awrcorp.com/Usa/Products/Optional-Products/TX-Line/>

This document is the exclusive property of AscenKorea Inc. and should not be distributed, reproduced, into any other format without prior permission of AscenKorea Inc. Specifications subject to change without prior notice.



## Appendix III: UART to RS232 Interface

Typically RS232 or USB interface is required to connect AscenKorea Inc. GPS module directly to the PC for communication. Majority of AscenKorea Inc. modules uses a set of communication port in TTL–logic (and a newer ones have support for direct USB connection) and a bridge IC is needed for conversion to RS232 level.

Please note the supported baud–rates are: 4800, 9600, 14400, 19200, 38400, 57600, and 115200 bps.

Please refer to the reference circuits below for such conversion: (using SP3320 IC as an example)

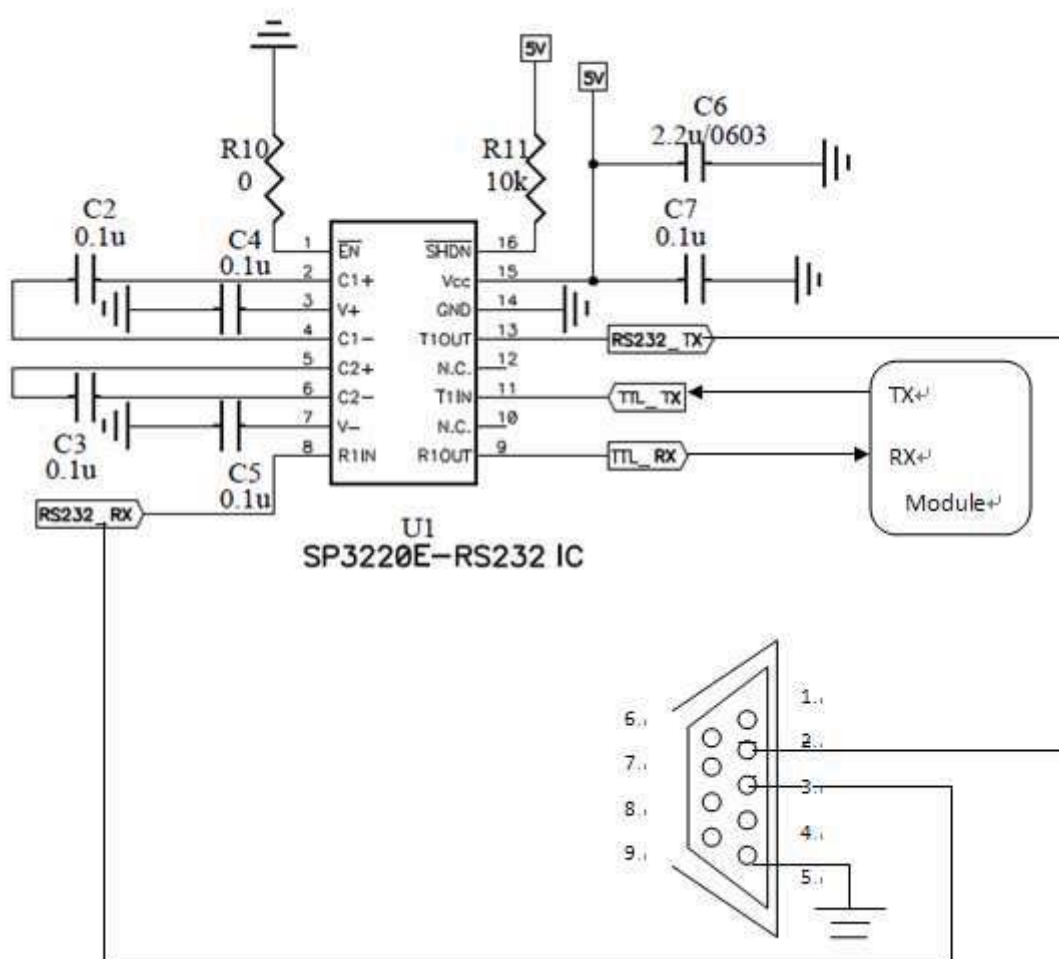

This document is the exclusive property of AscenKorea Inc. and should not be distributed, reproduced, into any other format without prior permission of AscenKorea Inc. Specifications subject to change without prior notice.

## Appendix IV: UART to USB Interface

If the AscenKorea Inc. module you have chosen does not contain USB interface or if you do not wish to use the integrated USB interface (perhaps due to driver or other concerns), it is possible to connect it to an external USB IC and further enhance the transferring speed by using a one capable of USB 2.0 interface. Once the driver for the chosen USB Bridge IC is successfully installed for Windows or other operating system, the USB Bridge IC will be automatically recognized as a com port within the operating system.

Note: proper driver must be installed or else the operating system will not be able to recognize the device!

Please refer to the reference circuits below for such conversion: (using CP2102 IC as an example)

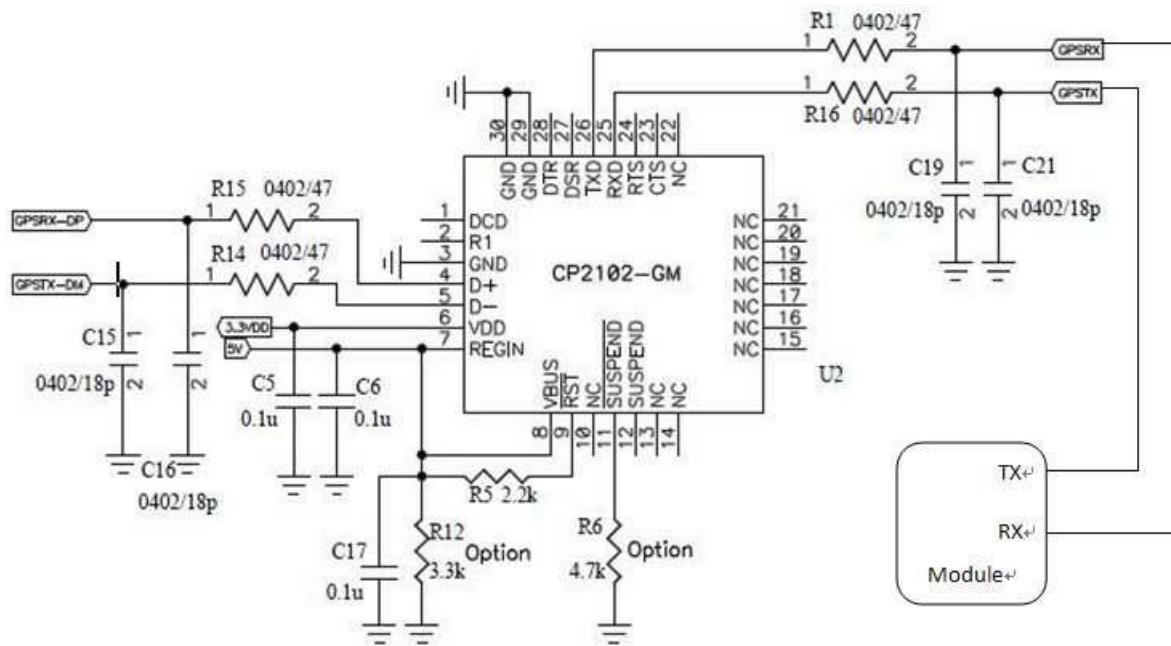

(The Pin29 and Pin30 are the bottom ground pads which not be listed in IC data sheet, customer could create the decal omitted this 2 pin)

## Appendix V: How to efficiently transfer 1PPS through extended distances

There are several things to watch out for when transferring 1PPS through long distances which will result in 1PPS signal degradation, noise and delays if proper attentions are not being paid. As the 1PPS signal passes through the communication cable, matching resistance must be implemented to prevent wave form distortions. Depending on user's application, OPA can be added to effectively control the accuracy of the voltage level determination for the 1PPS signal.

When using 1PPS signal to synchronize time, the OPA chosen should have a **high slew rate** property to prevent large delay in the 1PPS. The accuracy level of 1PPS for AscenKorea GPS module is within 100ns (same for majority of MTK GPS modules). The reference design below can help improving this accuracy to within 80ns.

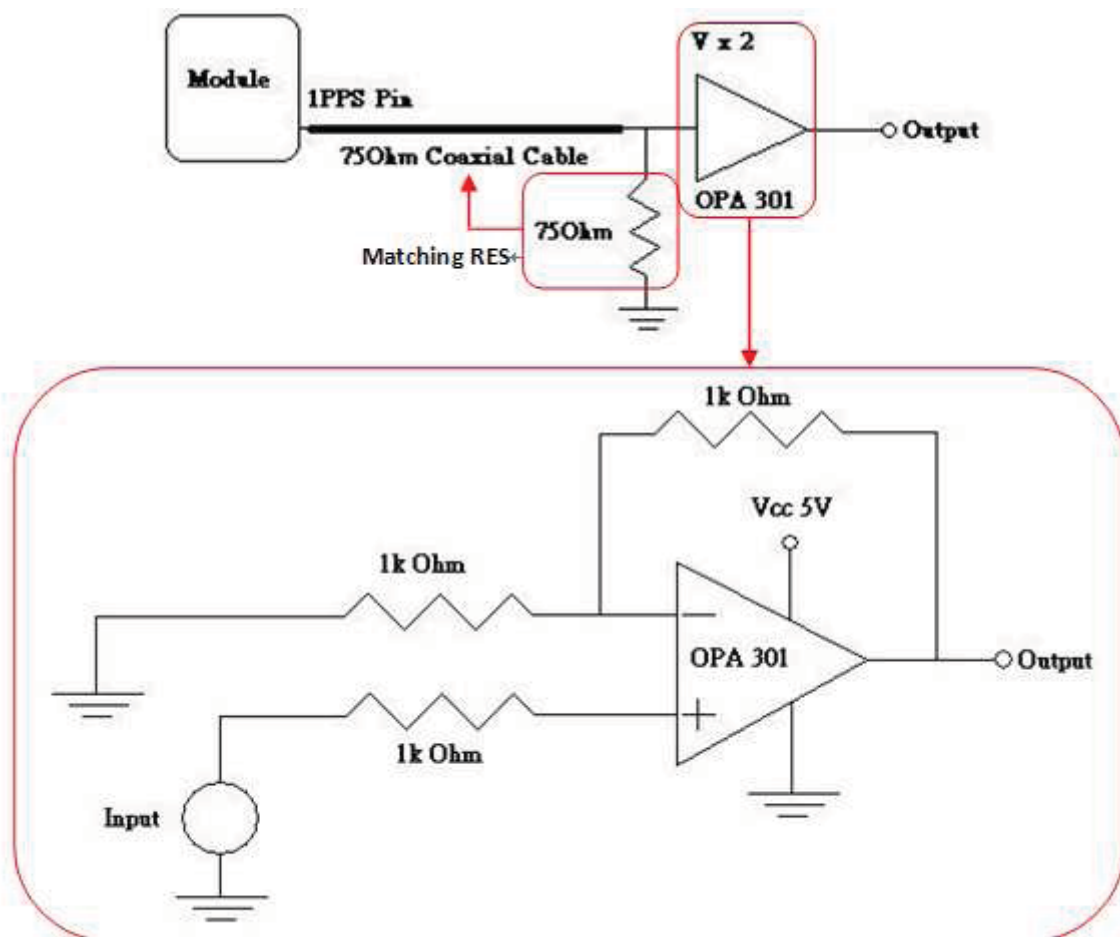

This document is the exclusive property of AscenKorea Inc. and should not be distributed, reproduced, into any other format without prior permission of AscenKorea Inc. Specifications subject to change without prior notice.



### 1PPS Delay Time :

Specifications of AscenKorea Inc. GPS modules call for a drift error within  $\pm 100\text{ns}$ , which the design below will help to accomplish.

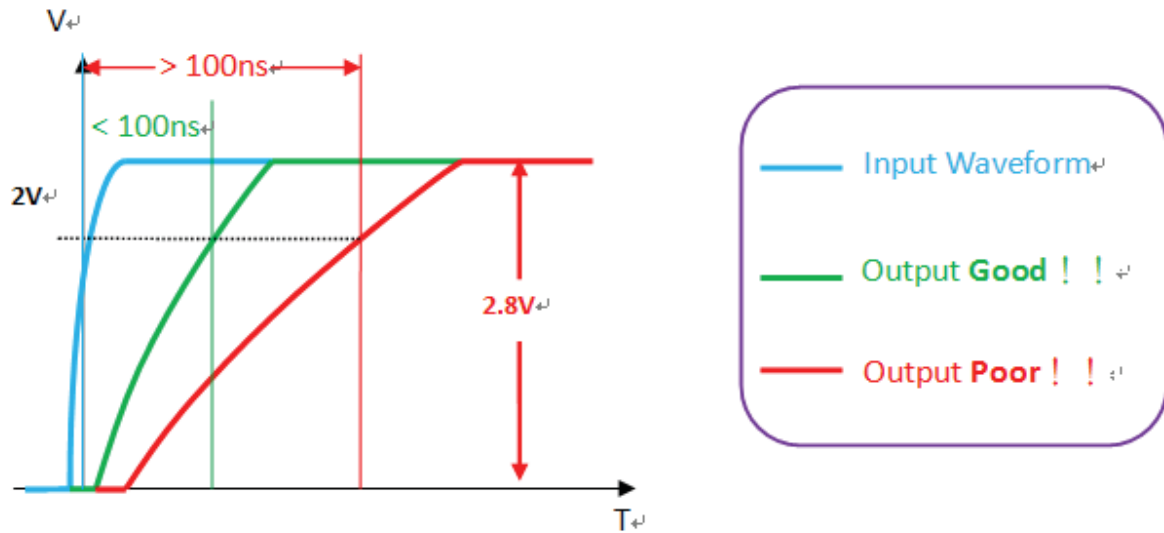

When using coaxial cable for long distances communication using OPA amplification, please pay close attention on the time delay caused by the coaxial cable and rising time of the wave form affected by OPA's SR. A brief explanation for this is provided below:



The model number for the coaxial cable is RG6U, where the figure below shows its specification.

## CONSTRUCTION

Item		A.Q.L.	Description
Conductor	No./mm	1.02 (± 0.025)	Copper clad steel
	1.02 CCS		
Insulation	No./mm	4.57 (± 0.20)	Foamed PE insulation
	4.57		
Shield	B-APA		Bonded double aluminium foil shield
	64/0.16(AL)	64 (±2); 0.16 (± 0.01)	Aluminium wire braid shield
	APA		Double aluminium foil shield
	48/0.16(AL)	48 (±2); 0.16 (± 0.01)	Aluminium wire braid shield
Jacket	No./mm	7.20 (± 0.30)	Black flame retardant PVC jacket
	7.20 PVC		

## DESIGN

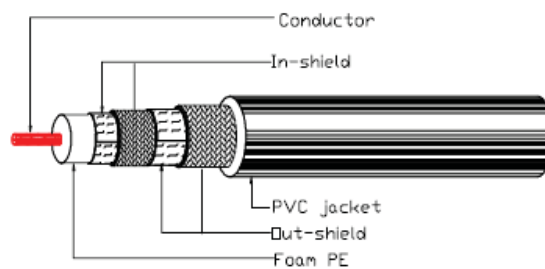

## CHARACTERISTICS

ITEM	Description	Standards	
Conductor Resistance	20°C, conductor DC resistance	<10Ω/100M	
Capacitance		53.2 ± 5pF/M	
Velocity Ratio		83 ± 3%	
Characteristic Impedance	20°C, 200MHz	75Ω ± 3Ω	
Return Loss	20°C, 5 --- 200MHz	>20dB	
Attenuation	20°C -dB/100M (± 10%)	55MHz	4.94
		211MHz	9.43
		400MHz	13.12
		870MHz	19.99
		1000MHz	21.46
		2000MHz	31.82

This document is the exclusive property of AscenKorea Inc. and should not be distributed, reproduced, into any other format without prior permission of AscenKorea Inc. Specifications subject to change without prior notice.



The delay time cause by the cable:

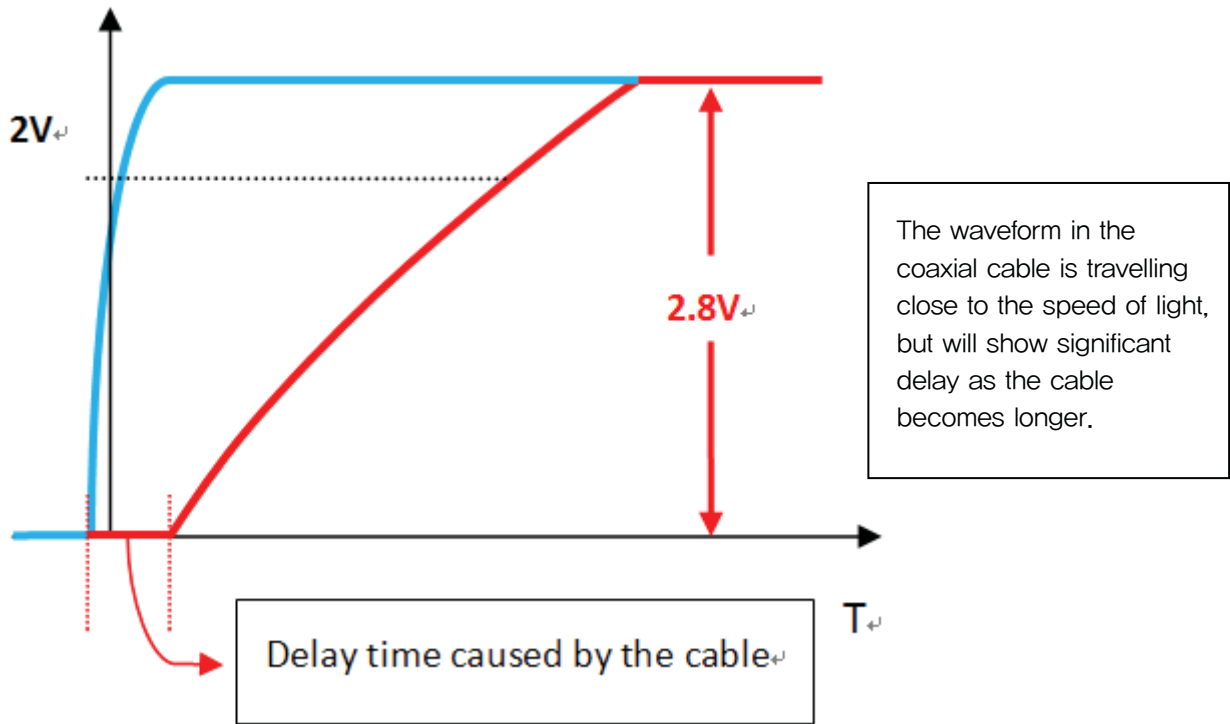

This document is the exclusive property of AscenKorea Inc. and should not be distributed, reproduced, into any other format without prior permission of AscenKorea Inc. Specifications subject to change without prior notice.



## How to calculate the delay time of the communication cable with the length of “N”

The simplest method to calculate this is to have a good grasp on the relationship between:

1. The speed of the waveform
2. The distance of the wave form traveled
3. The delay time

$$\frac{\ell}{\mu_p} = T$$

$\ell$  = Distance of the wave form traveled (m)

$\mu_p$  = Speed of the waveform (m/s)

$T$  = Delay Time (ns)

If the speed of the waveform (in coaxial cable) is unknown, it is possible to use a short sip of coaxial cable to test for this. For example, the signal travelling in 1 meter of coaxial cable can have its delay time measured by the oscilloscope as 5ns, and consequently the  $\mu_p$  will be  $2 * 10^8$  (m/s).

If the value of resistance and inductance for the coaxial cable is known, then perhaps  $\mu_p$  (m/s) can be calculated as well.

$$\mu_p = \frac{1}{\sqrt{LC}}$$

Moreover, fundamentals of electromagnetics such as RLCG parameters for the coaxial cable (including resistance, inductance, capacitance, and conductance), together with the inner and outer diameter of the cable, can be used in combination to perform theoretical calculations.

This document is the exclusive property of AscenKorea Inc. and should not be distributed, reproduced, into any other format without prior permission of AscenKorea Inc. Specifications subject to change without prior notice.



### Waveform rising time caused by OPA

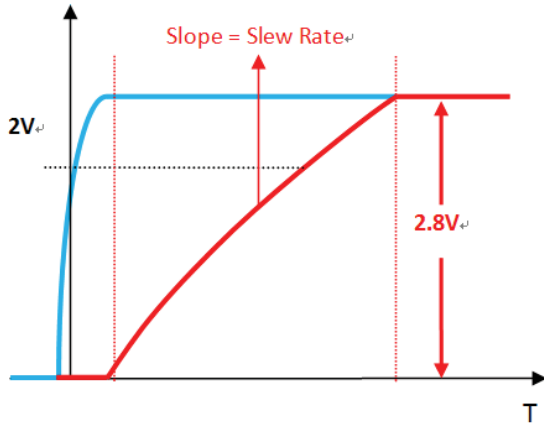

The left figure shows Slew Rate: which is the time needed for rising waveform. When the SR (V/μsec) of OPA is higher, the rising time will be shortened as well.

### Recommended OPA

If inadequate OPA is chosen (with low slew rate), the delayed caused by waveform rising time will be significantly longer than the delay in time caused by the coaxial wire.

We recommend using **OPA301** to decrease the waveform rising time

Specification of OPA301 :

©Low Power : 9.5mA(Typ) on 5.5V

©Single Power : 2.7V ~ 5.5V

©High Slew Rate : 80 V/msec

©Tiny Packages : MSOP and SOT23

### Voltage degradation of communication cable

We have tested a 10m long coaxial cable and only insignificant amount of voltage degradation is observed. Users should not be concerned with this issue.

This document is the exclusive property of AscenKorea Inc. and should not be distributed, reproduced, into any other format without prior permission of AscenKorea Inc. Specifications subject to change without prior notice.

## Appendix VI: Evaluation Kit (EV-KIT) Schematics

AscenKorea Evaluation Kit (EV-KIT for short) consists two parts: a base board that is similar across all models, and a daughter board that is model specific. In this appedix, the schematics of the base board and the daughter board for some of our popular models are included for design reference.

### Base Board:

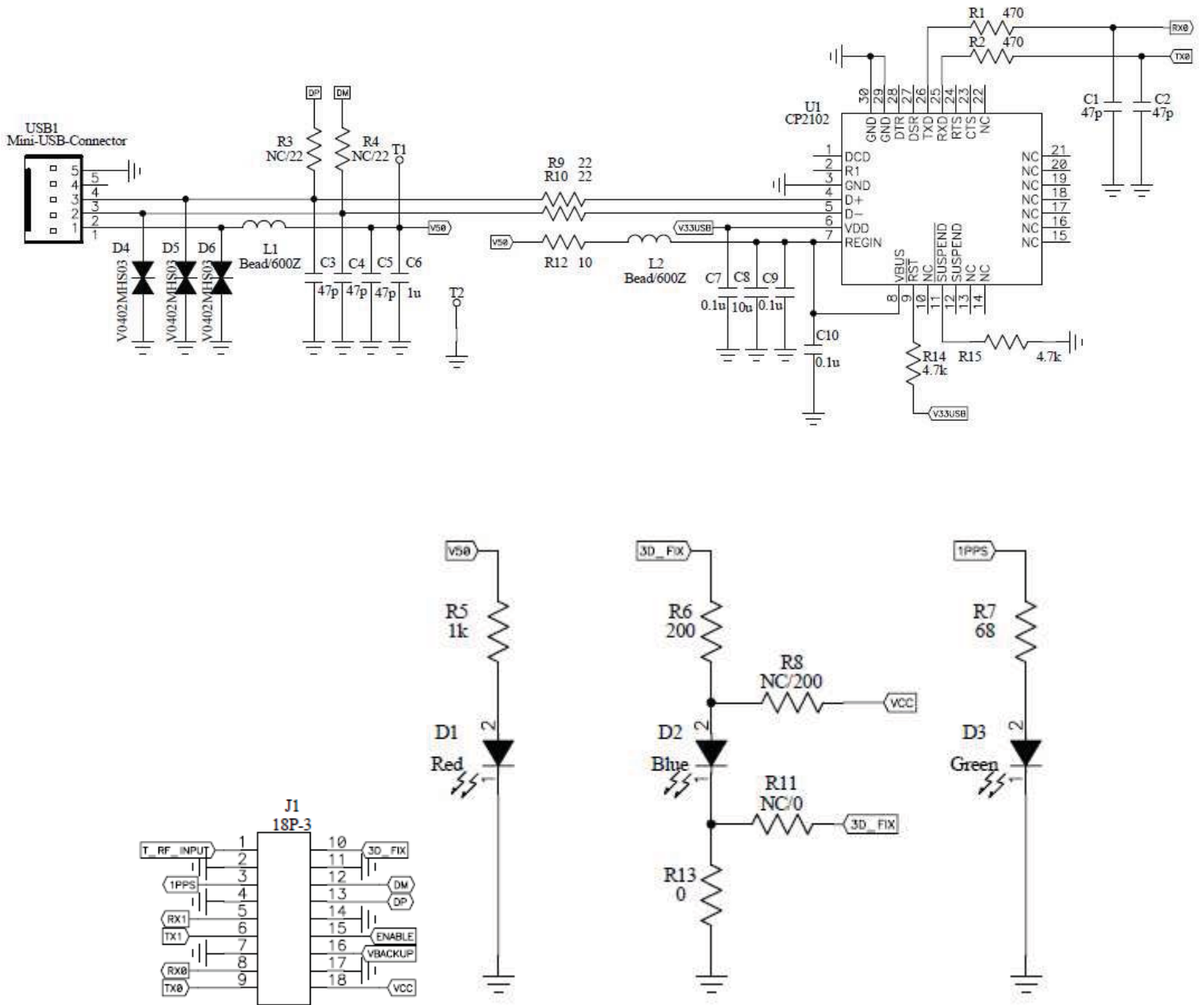

This document is the exclusive property of AscenKorea Inc. and should not be distributed, reproduced, into any other format without prior permission of AscenKorea Inc. Specifications subject to change without prior notice.



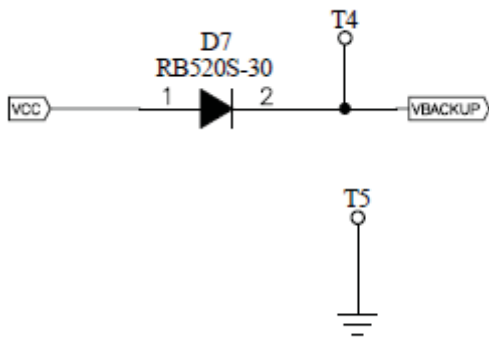
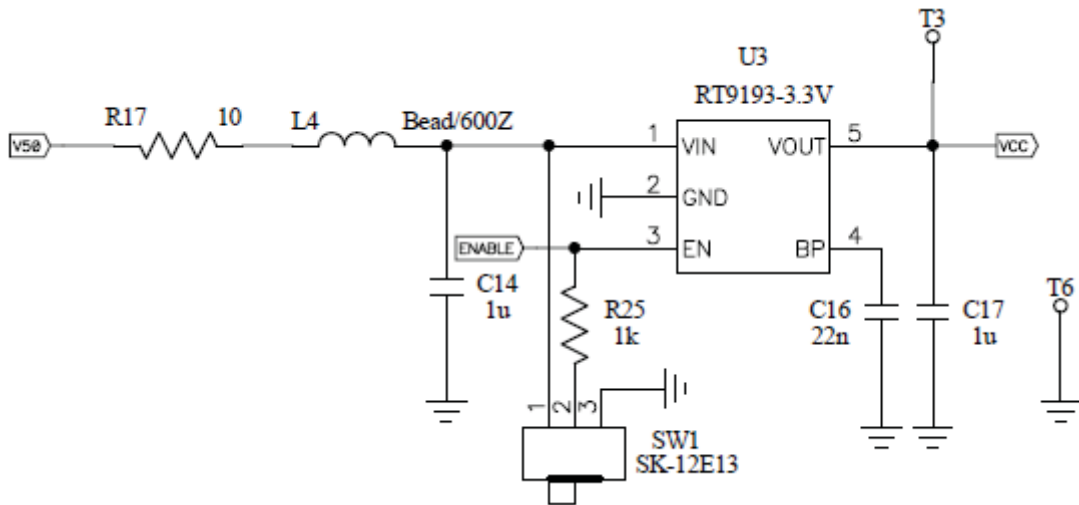
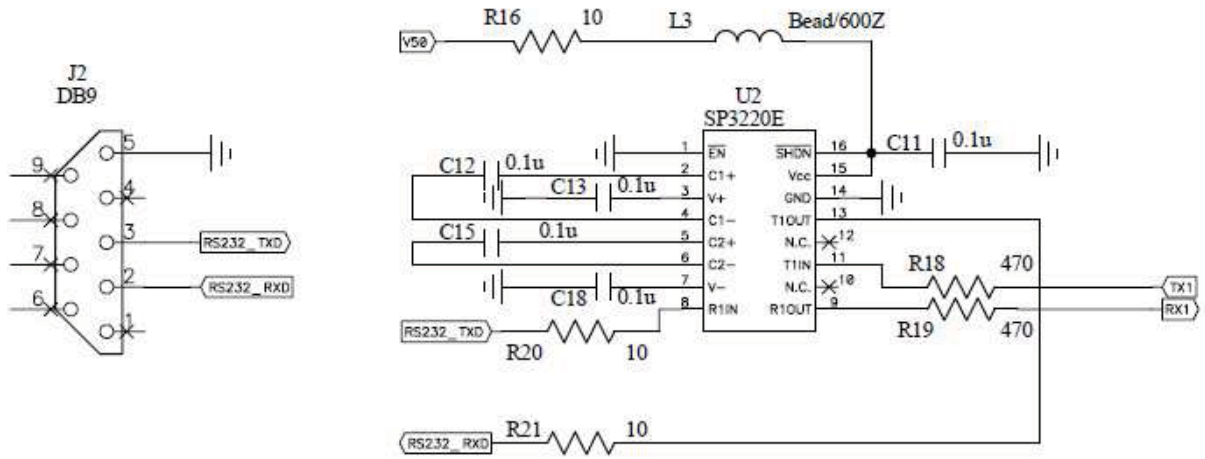
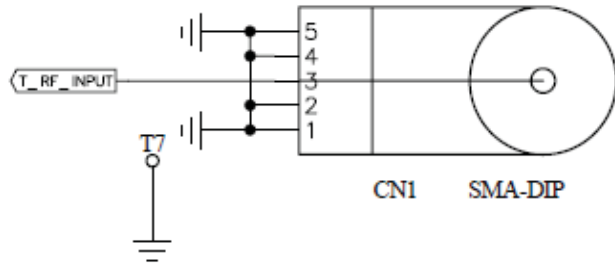

This document is the exclusive property of AscenKorea Inc. and should not be distributed, reproduced, into any other format without prior permission of AscenKorea Inc. Specifications subject to change without prior notice.



### AKS6B Base Board:

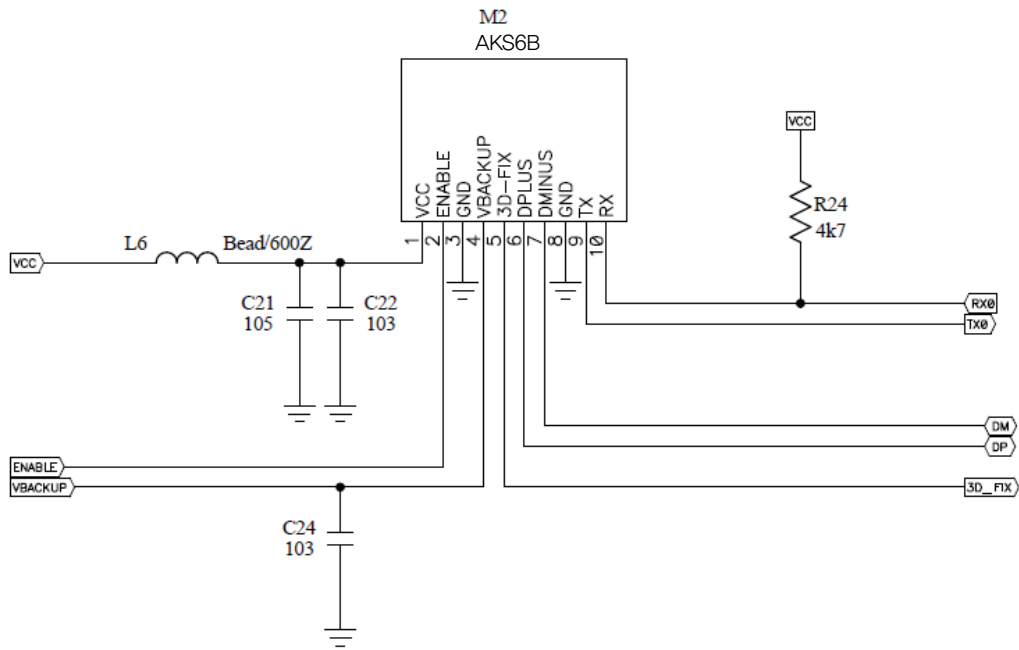

### AKS6E Base Board:

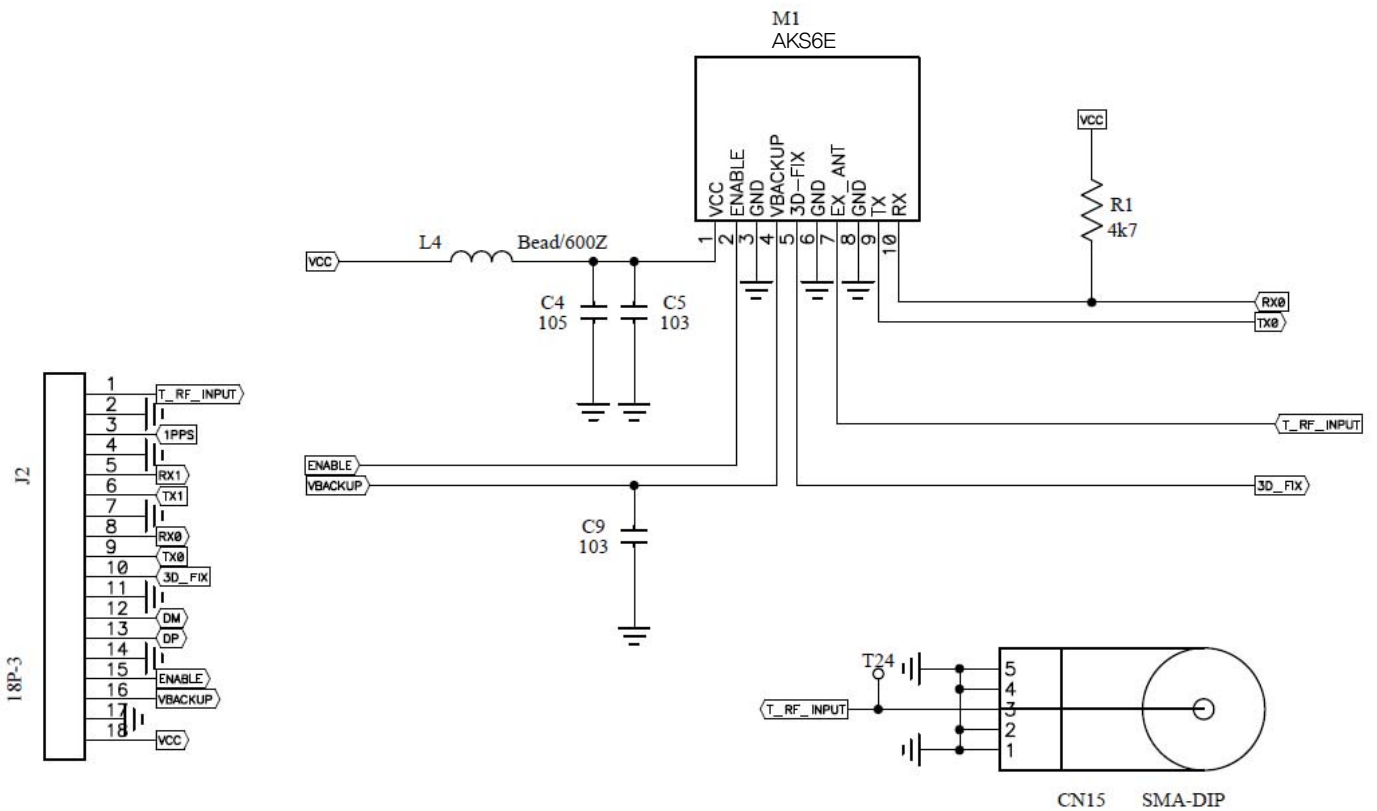

This document is the exclusive property of AscenKorea Inc. and should not be distributed, reproduced, into any other format without prior permission of AscenKorea Inc. Specifications subject to change without prior notice.

AscenKorea Inc.

Rm. 710, 7F, Halla Sigma Valley B/D, Gasandigital 2Ro 53, Geumcheon-gu, Seoul, Korea

Tel: +82 02 858 7810 Fax: +82 02 858 7813/ www.AscenKorea.com /sales@ascen.co.kr

copyright © AscenKorea Inc. All right reserved

### AKMU1 Daughter Board:

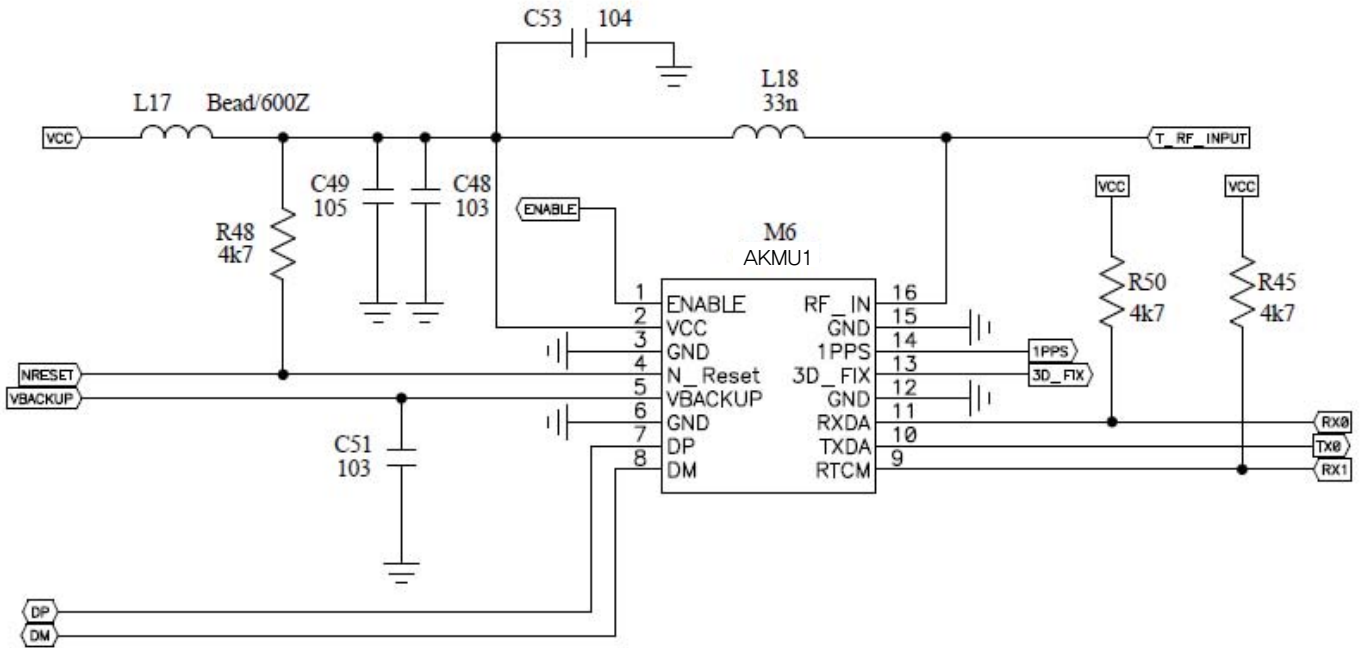

### AKSU1LP Daughter Board:

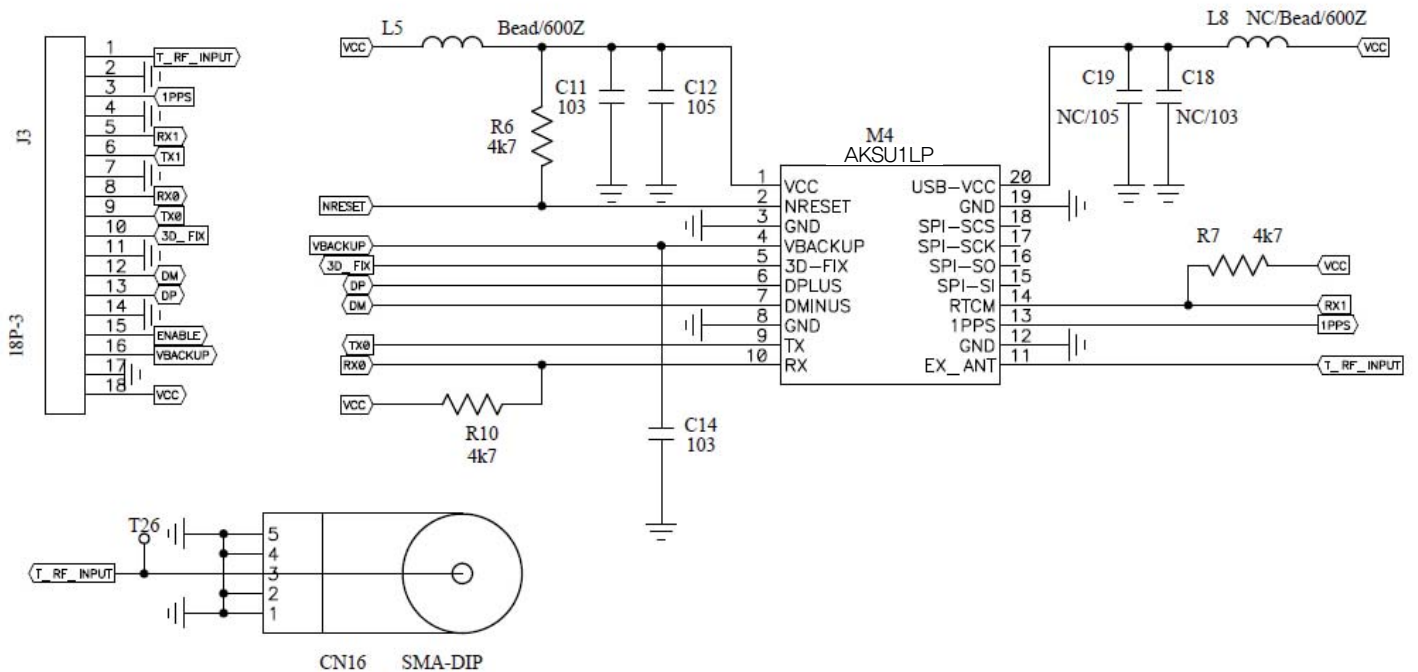

This document is the exclusive property of AscenKorea Inc. and should not be distributed, reproduced, into any other format without prior permission of AscenKorea Inc. Specifications subject to change without prior notice.



## Appendix VII: Cautions on Reflow Soldering Process

	Details	Suggestions	Notes
1	Before proceeding with the reflow-soldering process, the GPS module must be pre-baked.	Pre-bake Time: 6 Hours @ 60° ±5° C or 4 Hours @ 70° ±5° C	<b>The maximum tolerated temperature for the tray is 100°C.</b>  <b>After the pre-baking process, please make sure the temperature is sufficiently cooled down to 35°C or below in order to prevent any tray deformation.</b>
2	Because PCBA (along with the patch antenna) is highly endothermic during the reflow-soldering process, extra care must be paid to the GPS module's solder joint to see if there are any signs of cold weld(ing) or false welding.	The parameters of the reflow temperature must be set accordingly to module's reflow-soldering temperature profile.	<b>Double check to see if the surrounding components around the GPS module are displaying symptoms of cold weld(ing) or false welding.</b>
3	Special attentions are needed for PCBA board during reflow-soldering to see if there are any symptoms of bending or deformation to the PCBA board, possibility due to the weight of the module. If so, this will cause concerns at the latter half of the production process.	A loading carrier fixture must be used with PCBA if the reflow soldering process is using rail conveyors for the production.	<b>If there is any bending or deformation to the PCBA board, this might causes the PCBA to collide into one another during the unloading process.</b>
4	Before the PCBA is going through the reflow-soldering process, the production operators must check by eyesight to see if there are positional offset to the module, because it will be difficult to readjust after the module has gone through reflow-soldering process.	The operators must check by eyesight and readjust the position before reflow-soldering process.	<b>If the operator is planning to readjust the module position, please do not touch the patch antenna while the module is hot in order to prevent rotational offset between the patch antenna and module</b>

This document is the exclusive property of AscenKorea Inc. and should not be distributed, reproduced, into any other format without prior permission of AscenKorea Inc. Specifications subject to change without prior notice.



**Note :** References to patch antenna is referred to GPS modules with integrated Patch-on-top antennas (AKS Module Series), and may not be applicable to all GPS modules.

	Details	Suggestions	Notes
5	Before handling the PCBA, they must be cooled to 35° C or below after they have gone through the reflow-soldering process, in order to prevent positional shift that might occur when the module is still hot.	<p>1. Can use electric fans behind the Reflow machine to cool them down.</p> <p>2. Cooling the PCBA can prevent the module from shifting due to fluid effect.</p>	<b>It is very easy to cause positional offset to the module and its patch antenna when handling the PCBA under high temperature.</b>
6	<p>1. When separating the PCBA panel into individual pieces using the V-Cut process, special attentions are needed to ensure there are sufficient gap between patch antennas so the patch antennas are not in contact with one another.</p> <p>2. If V-Cut process is not available and the pieces must be separated manually, please make sure the operators are not using excess force which may cause rotational offset to the patch antennas.</p>	<p>1. The blade and the patch antenna must have a distance gap greater than 0.6mm.</p> <p>2. Do not use patch antenna as the leverage point when separating the panels by hand.</p>	<p><b>1. Test must be performed first to determine if V-Cut process is going to be used. There must be enough space to ensure the blade and patch antenna do not touch one another.</b></p> <p><b>2. An uneven amount of manual force applied to the separation will likely to cause positional shift in patch antenna and module.</b></p>
7	When separating panel into individual pieces during latter half of the production process, special attentions are needed to ensure the patch antennas do not come in contact with one another in order to prevent chipped corners or positional shifts.	Use tray to separate individual pieces.	<b>It is possible to chip corner and/or cause a shift in position if patch antennas come in contact with each other.</b>

**Note :** References to patch antenna is referred to GPS modules with integrated Patch-on-top antennas (AKS Module Series), and may not be applicable to all GPS modules.





## Other Cautionary Notes on Reflow-Soldering Process:

1. Module must be pre-baked **before** going through SMT solder reflow process.
2. The usage of solder paste should follow “first in first out” principle. Opened solder paste needs to be monitored and recorded in a timely fashion (can refer to IPQC for related documentation and examples).
3. Temperature and humidity must be controlled in SMT production line and storage area. Temperature of 23°C, 60±5% RH humidity is recommended. (please refer to IPQC for related documentation and examples)
4. When performing solder paste printing, please notice if the amount of solder paste is in excess or insufficient, as both conditions may lead to defects such as electrical shortage, empty solder and etc.
5. Make sure the vacuum mouthpiece is able to bear the weight of the GPS module to prevent positional shift during the loading process.
6. Before the PCBA is going through the reflow-soldering process, the operators should check by eyesight to see if there are positional offset to the module.
7. The reflow temperature and its profile data must be measured before the SMT process and match the levels and guidelines set by IPQC.
8. If SMT protection line is running a double-sided process for PCBA, please process GPS module during the second pass only to avoid repeated reflow exposures of the GPS module. Please contact AscenKorea beforehand if you must process GPS module during the 1st pass of double-side process.

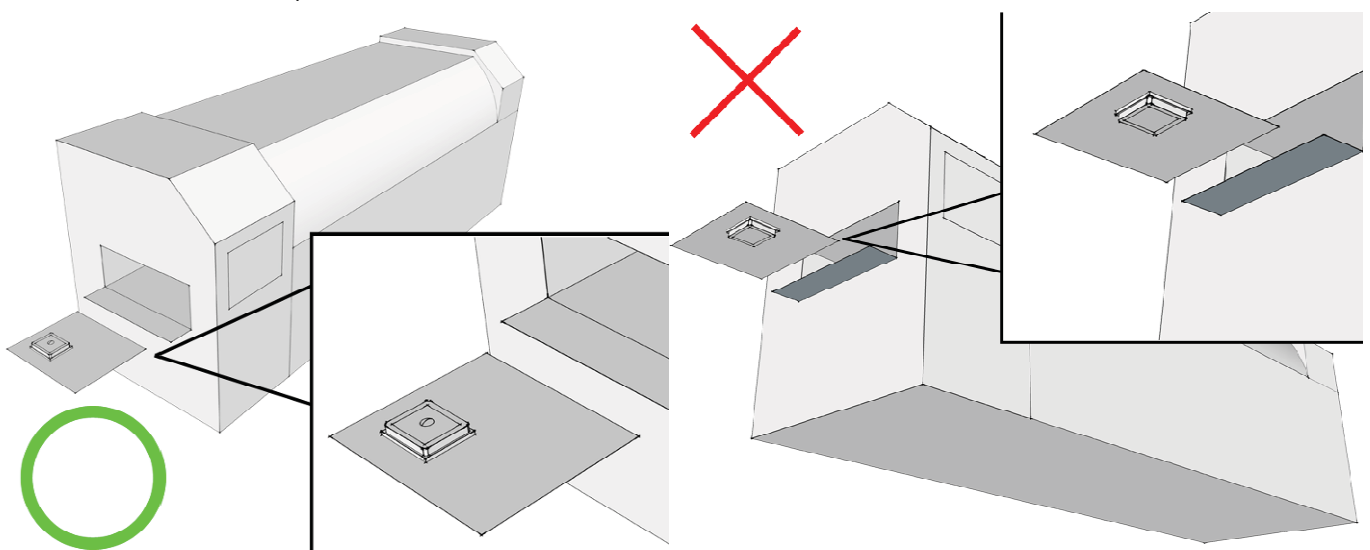

Figure 6.2: Place GPS module right-side up when running reflow-solder process, do not invert.

This document is the exclusive property of AscenKorea Inc. and should not be distributed, reproduced, into any other format without prior permission of AscenKorea Inc. Specifications subject to change without prior notice.



9. Module must be pre-baked **before** going through SMT solder reflow process.
10. The usage of solder paste should follow “first in first out” principle. Opened solder paste needs to be monitored and recorded in a timely fashion (can refer to IPQC for related documentation and examples).
11. Temperature and humidity must be controlled in SMT production line and storage area. Temperature of 23°C, 60±5% RH humidity is recommended. (please refer to IPQC for related documentation and examples)
12. When performing solder paste printing, please notice if the amount of solder paste is in excess or insufficient, as both conditions may lead to defects such as electrical shortage, empty solder and etc.
13. The reflow temperature and its profile data must be measured before the SMT process and match the levels and guidelines set by IPQC.

## **Manual Soldering**

### **Soldering iron:**

Bit Temperature: Under 380°C      Time: Under 3 sec.

### **Notes:**

1. Please do not directly touch the soldering pads on the surface of the PCB board, in order to prevent further oxidation
2. The solder paste must be defrosted to room temperature before use so it can return to its optimal working temperature. The time required for this procedure is unique and dependent on the properties of the solder paste used.
3. The steel plate must be properly assessed before and after use, so its measurement stays strictly within the specification set by SOP.
4. Please watch out for the spacing between soldering joint, as excess solder may cause electrical shortage
5. Please exercise with caution and do not use extensive amount of flux due to possible siphon effects on neighboring components, which may lead to electrical shortage.
6. Please do not use the heat gun for long periods of time when removing the shielding or inner components of the GPS module, as it is very likely to cause a shift to the inner components and will leads to electrical shortage.

This document is the exclusive property of AscenKorea Inc. and should not be distributed, reproduced, into any other format without prior permission of AscenKorea Inc. Specifications subject to change without prior notice.